

**Aberdeenshire**  
COUNCIL



## **TRANSPORTATION AND INFRASTRUCTURE**

### *STANDARDS FOR ROAD CONSTRUCTION CONSENT AND ADOPTION*

**Issue B – 16<sup>th</sup> May 2008**

## Contents

Contents.....	2
Drawing Index.....	9
Table Index.....	11
Part 1 POLICIES AND PROCEDURES.....	12
Preamble.....	12
1. The need for Consultation.....	13
1.1. Initial Consultation .....	13
1.2. Drainage.....	13
1.3. Consultation with Other Bodies .....	14
1.4. Consultation Certificates .....	14
2. Authority required to Construct New Roads .....	15
2.1. Necessary Consents .....	15
2.2. Planning Consents .....	15
2.3. Construction Consent .....	15
2.4. Design Requirements.....	15
2.5. Other Consents .....	15
2.6. Private Accesses .....	16
2.7. Provision of Roads.....	16
2.8. Works in an Existing Public Road.....	16
3. Policy regarding Adoption and Maintenance .....	17
3.1. Adoption of Roads.....	17
3.2. Phased Adoption.....	17
3.3. Adoption of Footpaths.....	17
3.4. Adoption and Maintenance of Parking Areas .....	18
3.5. Adoption and Maintenance of Road Lighting.....	18
3.6. Adoption and Maintenance of Traffic Signs .....	19
3.7. Structures Agreements.....	19
3.8. Road Bonds.....	19
3.9. Visibility Splays.....	20
4. Application for Construction Consent .....	21
4.1. Place and Date of Application .....	21
4.2. Granting of Consent with Conditions.....	21
4.3. Submission of Plans and Associated Documents.....	22
4.4. Drainage.....	24
4.5. Pipes and Culverts Under Roads (span or diameter less than 1.5 metres).....	24
4.6. Structures (including pipes and culverts with span or diameter greater than 1.5 metres) .....	24
4.7. Safety Audit .....	25
4.8. Responsibility for Design .....	25
4.9. Soil Report.....	25
4.10. Mineral Report.....	26
4.11. Docqueting of Plans.....	26
4.12. Notification of Owners .....	26
4.13. Owner's Objections .....	26
4.14. Hearing of Application .....	26
4.15. Construction Period .....	26
4.16. Right of Appeal .....	27
4.17. Amendments to Consent .....	27
4.18. Road Lighting .....	27
4.19. Road Bond .....	27
5. Inspection Procedures during Construction.....	28
5.1. Notice of Commencement.....	28
5.2. Inspection and Testing.....	28
5.3. Certificates of Testing.....	28
5.4. Certificates of Inspection.....	28
5.5. Notice of Operations.....	29
5.6. Inspection at Completion of Works.....	29
5.7. Recovery of Expenses .....	29
5.8. Reduction of Bond.....	30
5.9. Health and Safety.....	30

6.	Application for Adoption of New Roads and Footpaths .....	31
6.1.	Application for Adoption.....	31
6.2.	Footpaths .....	31
6.3.	Documents to Accompany Application .....	31
6.4.	Adoption Inspection .....	31
6.5.	Addition to List of Public Roads .....	31
6.6.	Release of Bond.....	31
Part 2 GEOMETRY AND LAYOUT .....		32
Preamble.....		32
7.	Use of Guidelines for Layout Design .....	33
7.1.	Consultation.....	33
7.2.	Guideline Principles .....	33
7.3.	Road Layout .....	33
7.4.	Road Types.....	33
7.5.	Parking and Service Areas.....	33
7.6.	Additional Design Consideration .....	33
7.7.	Future Development .....	34
7.8.	Infill Development.....	34
7.9.	Rural Areas.....	34
7.10.	Safety Audits .....	34
7.11.	Access Statements .....	34
8.	The Road Network.....	35
8.1.	Function .....	35
8.2.	Road Hierarchy.....	35
8.3.	Types of Road.....	35
8.4.	Infill Development.....	36
9.	Primary and District Distributor Roads .....	38
9.1.	Function.....	38
9.2.	Layout.....	38
9.3.	Geometry .....	38
9.4.	Verges.....	38
9.5.	Footways/Cycletracks.....	38
9.6.	Pedestrian Crossing Facilities.....	39
9.7.	Abnormal Loads .....	39
10.	Local Distributor Roads.....	40
10.1.	Function.....	40
10.2.	Layout.....	40
10.3.	Geometry .....	40
10.4.	Accesses.....	40
10.5.	Verges.....	40
10.6.	Footways/Cycletracks.....	40
10.7.	Pedestrian Crossing Facilities.....	41
11.	Industrial Access Roads.....	42
11.1.	Function .....	42
11.2.	Layout .....	42
11.3.	Geometry .....	42
11.4.	Footways/Cycletracks.....	42
11.5.	Verges.....	42
12.	Core Roads.....	43
12.1.	Function.....	43
12.2.	Layout .....	43
12.3.	Geometry .....	43
12.4.	Footways.....	43
12.5.	Verges.....	43
12.6.	Bus Route Provision.....	44
12.7.	Parking .....	44
13.	Housing Roads.....	45
13.1.	Function .....	45
13.2.	Layout .....	45
13.3.	Geometry .....	45
13.4.	Parking .....	45

14. Home Zones.....	46
14.1. Function.....	46
14.2. Legal Framework.....	46
14.3. Layout.....	47
14.4. Gateways.....	48
14.5. Cross Corner Visibility.....	48
14.6. Statutory Undertakers.....	48
14.7. Future Maintenance.....	48
15. Design Criteria.....	49
15.1. Design Criteria for Primary and District Distributor Roads (Table).....	49
15.2. Design Criteria for Local Distributor Road (Table).....	50
15.3. Design Criteria for Industrial Access Road (Table).....	51
15.4. Design Criteria for Core Road (Table).....	52
15.5. Design Criteria for Housing Road (Table).....	53
15.6. Design Criteria for Home Zones (Table).....	54
16. Forward Visibility.....	55
16.1. Standards.....	55
16.2. Measurement.....	55
16.3. Driver’s Eye Level.....	55
16.4. Target Height.....	55
16.5. Obstructions to Visibility.....	55
16.6. Stopping Sight Distance.....	55
17. Carriageway Widening on Curves.....	56
17.1. Need for Widening.....	56
17.2. Residential Roads.....	56
17.3. Method of Widening.....	56
18. Road Junctions.....	57
18.1. Form of Junction.....	57
18.2. Priority.....	57
18.3. Siting.....	57
18.4. Staggered Junctions.....	57
18.5. Geometry.....	57
18.6. Spacing.....	57
18.7. Major Road Visibility.....	57
18.8. Minor Road Visibility.....	58
18.9. Visibility Splay.....	59
18.10. Cross Corner Visibility.....	59
18.11. Special Cases.....	59
18.12. Gradients.....	59
18.13. Frontage Access/Parking.....	60
18.14. Dropped Kerbs.....	60
18.15. Unrestricted Major Road.....	60
18.16. Additional Requirements for Home Zones.....	60
18.17. Junction Markings.....	61
18.18. Roundabouts.....	61
19. Turning Areas.....	69
19.1. Turning Provision.....	69
19.2. Turning Areas.....	69
19.3. Geometry.....	69
19.4. Body Overhang.....	69
19.5. Parking.....	69
19.6. Informal Courtyards.....	69
20. Traffic Calming.....	73
20.1. General.....	73
20.2. Design Considerations.....	73
20.3. Environmental Considerations.....	73
20.4. Application/Hierarchy.....	74
20.5. Application on Distributor Roads.....	74
20.6. Application to Residential Roads.....	74
20.7. Types of Traffic Calming.....	74
20.8. Speed Cushion.....	75
20.9. Road Hump.....	75

20.10.	Speed Table .....	76
20.11.	Raised Junction.....	76
20.12.	Chicanes.....	77
20.13.	Pinch Points .....	77
20.14.	Pedestrian Refuges/Traffic Islands.....	78
20.15.	Carriageway Narrowings.....	78
20.16.	Speed Bend.....	78
20.17.	Lateral Shift in Alignment.....	79
20.18.	Overrun Corners .....	79
20.19.	Gateway on a Straight.....	79
20.20.	Side Road Gateway .....	80
21.	Provision for Pedestrians .....	96
21.1.	General.....	96
21.2.	Crossing Considerations.....	96
21.3.	At Grade Pedestrian Crossings.....	97
21.4.	Grade Separated Pedestrian Crossings .....	97
21.5.	Controlled Pedestrian Crossings.....	97
21.6.	Possible Enhancements to at Grade Pedestrian Crossings .....	97
21.7.	Routes on Distributor Roads .....	97
21.8.	Footway Widths.....	98
21.9.	Vehicular Footway Crossings.....	98
21.10.	Gradients.....	98
21.11.	Baffle Barriers .....	98
21.12.	Ramps and Steps.....	98
21.13.	Disabled Access to Buildings .....	99
21.14.	Obstacles to Pedestrian Routes.....	99
22.	Provision for Cyclists.....	101
22.1.	General.....	101
22.2.	Objectives .....	101
22.3.	Infrastructure Requirements .....	102
22.4.	Cycle Audit Procedure.....	102
22.5.	Definitions .....	103
22.6.	Format.....	103
22.7.	Signing.....	103
22.8.	Surface .....	103
22.9.	Junctions .....	104
22.10.	Parking .....	104
22.11.	Lighting.....	104
22.12.	Traffic Orders .....	104
23.	Rural Areas .....	106
23.1.	Introduction.....	106
23.2.	Hierarchy .....	106
23.3.	Road Width.....	106
23.4.	Development on Existing Roads .....	106
23.5.	Passing Places.....	106
23.6.	Junction Visibility Splays.....	107
24.	Making Up and Adoption of Private Roads .....	109
24.1.	Introduction.....	109
24.2.	Additions to the Statutory List of Public Roads .....	109
24.3.	Request for Addition to the Statutory List.....	109
24.4.	Section 13 Notice.....	109
24.5.	Appeals Against a Section 13 Notice .....	110
24.6.	Maintenance Period .....	110
24.7.	Required Standards.....	110
24.8.	Required Surface Condition .....	110
25.	Vehicular Access to Premises and Servicing Arrangements.....	113
25.1.	Access to Premises .....	113
25.2.	Service Roads .....	113
25.3.	Driveways.....	113
25.4.	Service Areas.....	113
25.5.	Kerbside Loading .....	114

26.	Car Park Provision .....	119
26.1.	Level of Provision and Adoption Criteria .....	119
26.2.	Rehabilitation.....	119
26.3.	Location.....	119
26.4.	Residents' Parking.....	119
26.5.	Visitors' Parking.....	119
26.6.	Walking Distances.....	120
26.7.	Bay Sizes .....	120
26.8.	Disabled Persons.....	120
26.9.	Car Park Layouts .....	120
26.10.	Large Car Parks .....	120
26.11.	Access.....	120
26.12.	Lay-by Parking .....	120
27.	Statutory Undertakers' Services .....	122
27.1.	Provision.....	122
27.2.	Routeing.....	122
27.3.	Routeing in Home Zones.....	122
27.4.	Location.....	122
27.5.	Service Corridors.....	122
27.6.	Road Furniture and Lighting .....	123
27.7.	Maintenance Access .....	123
27.8.	Fire Hydrants .....	123
27.9.	Carriageway Crossings.....	123
27.10.	Manholes .....	123
27.11.	Landscaping.....	123
27.12.	Location Plans .....	123
27.13.	Existing Services .....	124
27.14.	Installation of Services .....	124
28.	Additional Design Considerations.....	126
28.1.	Headroom .....	126
28.2.	Disabled Persons.....	126
28.3.	Bus Services .....	126
28.4.	Bus Stops .....	126
28.5.	Road Widths for Bus Routes.....	126
28.6.	Traffic Management .....	126
28.7.	Fire Fighting .....	127
28.8.	Refuse Collection .....	127
28.9.	Traffic Noise.....	127
28.10.	Traffic Noise.....	127
28.11.	Traffic Noise.....	127
28.12.	Clearances.....	127
28.13.	Safety Fences/Barriers.....	128
28.14.	Traffic Signs and Road Markings.....	129
28.15.	Street Name Plates.....	129
<b>Part 3 CONSTRUCTION DETAILS .....</b>		<b>132</b>
29.	Geotechnical Considerations .....	133
29.1.	Introduction.....	133
29.2.	Supporting Technical Documentation.....	133
29.3.	California Bearing Ratio (CBR).....	133
30.	Pavement Construction.....	134
30.1.	Specification .....	134
30.2.	Carriageway Construction .....	134
30.3.	Carriageway Construction .....	134
30.4.	Formation/Sub-Grade.....	134
30.5.	Sub-Grade Drainage .....	134
30.6.	Camber, Crossfall and Gradients.....	135
30.7.	Recycled Materials .....	135
30.8.	Two Stage Construction .....	135
30.9.	Tie in to Existing Carriageway.....	135
30.10.	Concrete Block Carriageway Paving .....	137
30.11.	Footway, Footpath and Cycletrack Construction.....	137

30.12.	Flexible Construction .....	137
30.13.	Concrete Slab Paving.....	137
30.14.	Small Element Slab Paving .....	138
30.15.	Block Paving.....	138
30.16.	In situ Concrete Paving.....	138
30.17.	Granolithic Concrete Paving .....	138
30.18.	Granite Slab Paving .....	138
30.19.	Kerbs and Edging .....	140
30.20.	Minor Accesses.....	140
30.21.	Residential Accesses.....	140
30.22.	Pedestrian Crossings.....	140
30.23.	Emergency Accesses .....	140
31.	Road Drainage .....	146
31.1.	Best Management Practices.....	146
31.2.	Sustainable Urban Drainage Systems.....	146
31.3.	Drainage Impact Assessment .....	146
31.4.	Appropriate Level of Treatment.....	147
31.5.	Road Drainage .....	147
31.6.	Footpath/Cycletrack Drainage.....	147
31.7.	Design of Piped Road Drainage .....	147
31.8.	Gully Spacing .....	148
31.9.	Lay-by Drainage .....	148
31.10.	Irregular Areas.....	148
31.11.	Gullies.....	149
31.12.	Connections .....	149
31.13.	Down Pipes.....	150
31.14.	Chambers .....	150
31.15.	Pipework.....	150
31.16.	Outfall Connection .....	150
32.	Road Lighting .....	152
32.1.	Application for Consent.....	152
32.2.	Information to be Supplied .....	152
32.3.	Inspections .....	152
32.4.	Specification .....	152
32.5.	Design .....	152
32.6.	Location of Apparatus .....	153
32.7.	Decorative Equipment .....	153
32.8.	Column Location .....	153
32.9.	Road Opening Permit .....	153
32.10.	Existing Services .....	153
32.11.	Maintenance.....	154
32.12.	Electricity Supply .....	154
32.13.	Electricity Supply .....	154
32.14.	Electricity Consumption.....	154
32.15.	Bond.....	154
33.	Traffic Signs and Road Markings.....	155
33.1.	Responsibility of the Developer .....	155
33.2.	Design and Siting of Traffic Signs .....	155
33.3.	Road Markings .....	155
33.4.	Street Name Plates.....	156
33.5.	Alterations to Existing Signage .....	156
34.	Road Landscaping .....	157
34.1.	Specification .....	157
34.2.	Design .....	157
34.3.	Soft Verge.....	157
34.4.	Topsoil .....	157
34.5.	Grass Seed .....	157
34.6.	Hard Verges.....	157
35.	Contact Names and Addresses .....	158
36.	Glossary .....	159
37.	Bibliography .....	162
38.	Safety Audit Stages.....	163

39. Accessible Design and Access Audits.....	166
39.1. Policy Statement .....	166
39.2. Design Standards .....	166
39.3. Departures from Desirable Standards.....	166
39.4. Access Audits .....	166
39.5. Access Auditor .....	167
39.6. Access Audit Procedure.....	167
39.7. Access Audit Brief.....	167
39.8. Audit Report .....	168
39.9. Designer’s Response.....	168
39.10. Dispute Resolution .....	169
39.11. Project Access Statement.....	169
39.12. Maintenance and Repair .....	169
39.13. Sample Audit Brief and Schedule .....	170
39.14. Audit Report Summary Sheet.....	173
Appendix A – List of Consultees .....	174
Appendix B – Design and Check Certificates .....	175
Design Certificate .....	176
Confirmation of Appointment of Designer .....	177
Check Certificate .....	178
Safety Audit - Stage 1/2/3* Road Safety Audit Certificate.....	179

## Drawing Index

Figure 8.1	Sample Layout of General Access Roads and Culs-de-Sac	37
Figure 18.1	General Layout of a Priority Junction	64
Figure 18.2	Dropped Kerbs at Road Junctions	65
Figure 18.3	Typical Home Zone Entry Detail	66
Figure 18.4	Markings for use with Give Way Sign	67
Figure 18.5	Markings for No Give Way Sign	68
Figure 19.1	Industrial Turning Circle and Banjo	70
Figure 19.2	Industrial and Residential Hammerheads	71
Figure 19.3	Industrial and Residential Road Stubs	72
Figure 20.1	Round Topped Road Hump	81
Figure 20.2	Speed Table	82
Figure 20.3	Tapered Edge Speed Table and Road Hump	83
Figure 20.4	Speed Cushion	84
Figure 20.5	Road Hump Typical Construction Details	85
Figure 20.6	Raised Junction	86
Figure 20.7	Chicane Type 1	87
Figure 20.8	Chicane Type 2	88
Figure 20.9	Chicane Type 3	89
Figure 20.10	Pinch Point	90
Figure 20.11	Central Island	91
Figure 20.12	Width Reduction in Carriageway	92
Figure 20.13	Speed Bend	93
Figure 20.14	Lateral Shift in Alignment	94
Figure 20.15	Overrun Corners	95
Figure 21.1	Typical Baffle Barrier Layout	100
Figure 22.1	“Sheffield” Cycle Racks	105
Figure 23.1	Typical Passing Place Detail	108
Figure 25.1	Typical Footpath Construction	115
Figure 25.2	Kerb Details	116
Figure 25.3	Vehicular Footway Crossings	117
Figure 25.4	Dropped Kerb Detail at Designated Pedestrian Crossing Point	118
Figure 26.1	Off-Road Parking Areas	121
Figure 27.1	Location of Service Mains	125

Figure 28.1	Street Name Plate Layout	130
Figure 28.2	Bus Stop Kerb Detail	131
Figure 30.1	Capping and Sub-Base	141
Figure 30.2	Longitudinal Tie in Details	142
Figure 30.3	Carriageway Widening – Tie in Detail	143
Figure 30.4	Buff Tactile Paving	144
Figure 30.5	Typical Carriageway and Footway Construction	145
Figure 31.1	Typical Road Gully	151

## Table Index

Table 15.1	Design Criteria for Primary and District Distributor Roads	49
Table 15.2	Design Criteria for Local Distributor Road	50
Table 15.3	Design Criteria for Industrial Access Road	51
Table 15.4	Design Criteria for Core Road	52
Table 15.5	Design Criteria for Housing Road	53
Table 15.6	Design Criteria for Home Zones	54
Table 16.1	Stopping Sight Distance	55
Table 17.1	Carriageway Widening on Curves	56
Table 18.1	Dimensions for Priority Junctions	58
Table 18.2	Cross Corner Visibility Requirements	59
Table 22.1	Cycle Track Widths	103
Table 23.1	Road Widths	106
Table 23.2	Speed Limit – Y Distance	107
Table 24.1	Adoption Criteria – Urban Private Roads	111
Table 24.2	Adoption Criteria – Rural Private Roads	112
Table 25.1	Service Road Widths for Kerbside Loading	114
Table 30.1	Carriageway Construction	136
Table 30.2	Footway and Footpath Construction	139
Table 31.1	Gully Spacing for Carriageways	149

## **Part 1 POLICIES AND PROCEDURES**

### Preamble

Part 1 of the guidelines is intended to assist private and public developers in obtaining the necessary authority, which is required before a new road is constructed and, subsequently, in having the new road adopted by the Local Roads Authority.

## 1. The Need for Consultation

### Initial Consultation

- 1.1 It is important that developers consult the appropriate staff of the Transportation and Infrastructure Service, as listed in section 35, at an early stage in their preparations as:
- (a) the location chosen for development may not be suitable for the type of development envisaged in terms of access and/or may be affected by future road schemes;
  - (b) the proposed layout may not be acceptable in relation to planning requirements;
  - (c) adjustments to the layout may be necessary to meet Construction Consent requirements;
  - (d) some discretionary powers are available and the Local Roads Authority's Representative may advise developers in respect of variation to the Specification to suit specific local conditions;
  - (e) adjustments to the lighting design may be necessary to meet Construction Consent requirements and the Local Roads Authority's Representative will specify the manufacture and type of lantern along with the type and size of lamp consistent with the standard.

If not noted at an early stage, any of the above possibilities could result in considerable abortive works and expense to the Developer.

**Initial consultation with staff of the Transportation and Infrastructure Service is provided free of charge and Developers should ensure that they contact the appropriate office at an early stage.**

### Drainage

- 1.2 Developers should consult Scottish Water and the Scottish Environmental Protection Agency (SEPA) at an early stage for advice on the requirements for foul and surface water drainage and of the location and suitability of outfalls.

It should be noted that early consultation with Transportation and Infrastructure and the above bodies will be required in relation to the suitability of the site for the incorporation of a Sustainable Urban Drainage System (SUDS), and this should be carried out at an early stage.

Issue B

Consultation with  
Other Bodies 

1.3 The information contained in these guidelines refers principally to the Local Roads Authority requirements. The requirements of the Planning Authority, Public Transport Unit, Statutory Undertakers, Grampian Fire Brigade, Scottish Ambulance Service, Chief Constable, Scottish Water and Scottish Environmental Protection Agency (SEPA) will be extra to these requirements and should be checked out individually at an early stage.

Consultation  
Certificates 

1.4 The Developer is required to provide the Local Roads Authority with completed Consultation Certificates before Construction Consent can be granted. Lists of the required Consultees are included in Appendix A.

## 2. Authority required to Construct New Roads

### Necessary Consents

- 2.1 Before undertaking any new road construction the Developer must obtain both Detailed Planning Consent and Construction Consent.

**It should be noted that the granting of one does not necessarily imply the granting of the other.**

### Planning Consent

- 2.2 Planning Consent is granted by the Local Planning Authority from whom further advice should be sought.

### Construction Consent

- 2.3 In terms of Section 21 of the Roads (Scotland) Act 1984, any person or organisation other than a Roads Authority who wishes to construct a new road or an extension of an existing road must obtain Construction Consent, irrespective of whether or not such roads are to be submitted for adoption as public. Construction Consent is granted by the Local Roads Authority and **road construction works may only be undertaken while the Construction Consent (Form CC3) remains valid.**

Section 151-(1) of the Roads (Scotland) Act 1984 states:

“road” means, (.....), any way (other than a waterway) over which there is a public right of passage (by whatever means) and includes the road’s verge, ..... etc.

### Design Requirements

- 2.4 Construction Consent will be granted only where proposals for the layout and construction of roads, structures, road drainage and lighting meet the Local Roads Authority’s standards. Guidance as to how these standards should be achieved is contained in this document: Geometric and Layout Details in Part II; Construction Details in Part III. Since economy of maintenance will be a major consideration in the assessment of applications for Construction Consent, the use of structures to support roads (e.g. retaining walls and bridges) should be avoided wherever possible. Structures will require the appropriate authorisation including approval in principle of the structure and the method of analysis.

Recent policy initiatives will result in the majority of domestic housing development roads being the subject of a mandatory 20mph speed limit zone. Developers will be required to design layouts in such a manner as to ensure that this speed limit is self-enforcing.

### Other Consents

- 2.5 The granting of Construction Consent does not exempt the applicant from obtaining any other permissions, which may be required such as Planning Consent or approval for connection to a sewer.

Private  
Accesses 

2.6 A Private Access is defined as any way over which the public does not have a right of passage. In residential development an access may serve up to five dwellings.

Provision of  
Roads 

2.7 6 or more individual dwellings should normally be served by a road, which will require Construction Consent and the submission of a Road Bond in a residential area.

If the Developer wishes to adopt a layout whereby 5 or less dwellings will be served by a Private Access, as there is no public right of access Construction Consent will not be required and the access will not be eligible for adoption. Such layouts should provide adequate turning facilities and a satisfactory junction with a public road. The provision of a Private Access must be indicated clearly at the planning application stage, otherwise it will be considered that a road is being provided.

Works in an  
Existing Public  
Road 

2.8 Any works in an existing public road will require permission from the Roads Authority under Section 56 of the Roads (Scotland) Act 1984. This is in addition to the Construction Consent and will always apply where a new road joins into an existing public road. Application forms should be obtained from the Council's office or from the website.

### 3. Policy regarding Adoption and Maintenance

#### Adoption of Roads

3.1 In terms of Section 16 of the Roads (Scotland) Act 1984, the Local Roads Authority will, upon request, adopt – i.e. add to its list of public roads and maintain thereafter – any new road (including any associated footway, cycle track or verge) constructed in accordance with Construction Consent.

#### Phased Adoption

3.2 To avoid long delays between construction and adoption of roads, developers are recommended to programme construction to enable the adoption of roads to be phased as sections of work are completed, subject to the following conditions: -

- (a) Carriageways, footways, cycle tracks, street lighting and verges will not be adopted separately;
- (b) In general only lengths of road between junctions or completed culs-de-sac will be adopted.
- (c) All roads submitted for adoption should form a continuous system with existing roads.
- (d) They should serve a public need.

#### Adoption of Footpaths

3.3 In terms of Section 18 of the Roads (Scotland) Act 1984, the Local Roads Authority, will upon request, adopt any footpath which is the subject of an Agreement. The suitability of footpaths, for adoption will be judged against the following criteria:

- (a) They should be constructed in accordance with a Construction Consent;
- (b) They should form part of a general pedestrian network interconnecting houses, shops, schools, public transport etc. and must be available for public use on an unrestricted basis;
- (c) Footpaths should either join two public places or serve more than one individual dwelling.
- (d) Where footpaths lead to both front and rear of houses, in general, only one will be adopted unless they serve another public purpose;
- (e) Surfaced areas surrounding buildings and intended for maintenance purposes will not be considered for adoption.
- (f) A network of footpaths should abut the public road at one end at least at one point, to facilitate access for maintenance purposes;
- (g) Arrangements of steps which prevent access to isolated lengths of footpath should be avoided if practicable.

Adoption and  
Maintenance of  
Parking Areas 

- 3.4 In both new development and redevelopment, the developer will normally be required to provide parking spaces off the carriageway in accordance with the current Aberdeenshire Council parking standards. The suitability of such areas for adoption and maintenance by the Local Roads Authority will be judged against the following criteria:
- (a) Parking area contiguous to the carriageway will normally be adopted as public roads provided that their use by the general public is not restricted in any manner and should be additional to residents' off-street parking, garages and drives.
  - (b) Off-road parking areas, which have been identified as meeting a general public parking need and have been constructed in accordance with Construction Consent, may be taken over in certain circumstances. For such an area to be taken over the Developer must enter into an agreement with the Local Roads Authority whereby the ground will heritably vest in the Local Authority.
  - (c) Private parking areas provided in lieu of garages or private drives and restricted to use by residents will not be taken over for maintenance purposes by the Local Roads Authority and must therefore be subject to private maintenance agreements. Accesses to such areas from the prospective public road must be designed and constructed so as to leave no ambiguity about the boundary of the publicly maintainable area.

Adoption and  
Maintenance of  
Road Lighting 

- 3.5 Lighting installations on publicly maintainable roads and footpaths will be taken over by the Local Roads Authority for operation and maintenance from the date of formal adoption for the roads, provided that they have been installed in accordance with a Construction Consent and to the satisfaction of the Local Roads Authority's Representative. The Developer will be required to submit the necessary Test Certificates to confirm that the electrical installations have been installed in accordance with national standards.

Until the lighting system is formally adopted the developer will be responsible for all charges relating to the operation of the lighting installations. The Developer will be obliged to submit evidence of agreements with an electricity supplier and a suitable maintenance contractor.

The Local Roads Authority may be willing to provide these services on a fully rechargeable basis.

Adoption and  
Maintenance of  
Traffic Signs 

- 3.6 Traffic signs on publicly maintainable roads and footpaths will be taken over by the Local Roads Authority from the date of formal adoption for the roads, provided that they have been installed in accordance with Construction Consent and to the satisfaction of the Local Roads Authority's Representative.

It should be noted that the regulatory signs, such as Give Way and Stop signs, and street nameplates should be installed prior to the occupation of the first property served by a particular road within the development. The temporary installation of an approved sign will be acceptable at the discretion of the Local Roads Authority's Representative.

Structures  
Agreements 

- 3.7 Where Construction Consent provides for a road to be supported by a structure, the Local Roads Authority will normally enter into an agreement with the developer, in terms of Section 79(1) (c) of the Roads (Scotland) Act 1984, whereby the bridge will heritably vest in the Local Roads Authority. Other essential structures will also require an agreement to enable these structures and soliums to vest in the Local Roads Authority. However, where a bridge or other structure and solium have not been so acquired, the Local Roads Authority will be responsible only for maintaining the road surface.

Retaining walls should only be used in exceptional circumstances at the discretion of the Local Roads Authority's Representative. Walls constructed to support the road (at the time of road construction) will normally be adopted. Walls constructed to retain adjacent ground and/or forming part of a building will not be adopted.

Road Bonds 

- 3.8 In terms of the Roads (Scotland) Act 1984 and the Security for Private Road Works (Scotland) Regulations 1985, (S.I. 2080), as amended by The Security for Private Road Works (Scotland) Amendment Regulations 1998, (S.I. 3220), developers are required to make financial provision with the Local Roads Authority in order to safeguard the completion of housing development roads which are the subject of Construction Consent. Such provision, which may take the form of a "Road Bond" or deposit, protects prospective house purchasers from having to bring incomplete roads up to adoptable standards. **It should be noted that no building works can commence until such securities have been lodged.**

A security in favour of the Local Roads Authority will also require to be lodged as part of any agreement whereby substantial works affecting the existing public road network are being undertaken by private bodies.

- 3.9 In general Visibility splays at junctions will form part of the road and thus be adopted. There must be a permanent and continuous demarcation of the boundary between the verge and adjoining property (e.g. by a fence, wall or concrete edge kerbing). In most circumstances any footway should be located at the rear of the splay.

Cross corner visibility splays need not always form part of the road and in these cases will not be adopted. However they will only be acceptable if they are subject to a Planning condition restricting the height of any future potential restriction to visibility i.e. hedges or fences. Additionally, in terms of Section 83(1) (b) an obstruction notice will be served on the developer. The developer must ensure that the restrictions outlined in the notice are contained within the title deeds to that plot and must submit a copy of such to the Local Roads Authority.

## 4. Application for Construction Consent

Place and Date  
of Application 

- 4.1 An application for Construction Consent should be made on **Form CC1**, obtainable at the Transportation and Infrastructure offices listed in Section 35. **Completed application forms should be submitted at least three months prior to the intended commencement of construction** to the Local Roads Authority's Representative appropriate to the locality of the development.

The application for Construction Consent should demonstrate how the proposed road layout integrates with both the existing public road network and possible adjacent future developments. This will require consultation with the Local Planning Authority.

The Consent area may be phased and the value of the Road Bond will be relative to each phase. However, each section must be able to provide traffic turning within the section.

The Developer must indicate the period required for Construction Consent (See Section 4.15).

It should be noted that the Construction Consent is not transferable. Should another Developer take over the control and development of the site a new Construction Consent must be obtained. An agent can act on behalf of a Developer although the consent will be issued in the name of the Developer. The Local Roads Authority's Representative must be advised of the Agent at the time of application and of any subsequent changes.

Granting of  
Consent with  
Conditions 

- 4.2 Under the terms of Section 21(3) of the Roads (Scotland) Act 1984 the Local Roads Authority may "grant construction consent either without conditions or subject to such conditions as they think fit". Any such conditions form an integral part of the Construction Consent and failure to comply with any such conditions is an offence, which shall be triable either summarily or on indictment.

A condition relating to construction period will be included in every Construction Consent, in accordance with Section 21(4) of the Roads (Scotland) Act 1984. (See Section 4.15)

4.3 Applications for Construction Consent should be accompanied by **four paper copies of detailed working drawings folded to A4 size** and other associated documents which should include the following information:-

- (a) **A location plan**, showing proposed development on the Ordnance Survey base, to a scale of 1:1250 or 1:2500, showing the proposed road network and its relationship to existing development.
- (b) **A layout plan** of the carriageways, footways, cycle tracks, verges, footpaths, retaining walls, bridges or other structures and earthworks to a scale of 1:500 (1:200 where pedestrian/vehicle/cycle shared surfaces are proposed) showing:
  - (i) The proposed centre, building and kerb lines (and also the heel of the footway where this differs from the building line);
  - (ii) Curve radii of the road alignment and junctions;
  - (iii) Dimensioned visibility splays at road junctions;
  - (iv) Vehicular access points to properties;
  - (v) Pedestrian crossing points at junctions and other locations where dropped kerbs will be located;
  - (vi) Cycle crossing points with dropped kerbs where shared use facilities are proposed;
  - (vii) The location of all road gullies including connections to sewer;
  - (viii) The location of the road drainage system and its discharge points;
  - (ix) The location and type of lighting columns and lanterns, wall mounted lighting units (if applicable), control pillars, underground cables and road crossing ducts;
  - (x) The location of all underground services and ancillary apparatus;
  - (xi) The full extents of all cut and fill slopes;
  - (xii) The boundaries of any areas which it is intended will subsequently be offered for adoption or maintenance;
  - (xiii) The layout and specification of all road markings, signs, street name plates and traffic signals;
  - (xiv) Precise site limits;
  - (xv) Ground floor levels;
  - (xvi) Details of SUDS system;
  - (xvii) Driveway gradients;
  - (xviii) Locations of traffic calming measures;
  - (xix) Landscaping layout showing locations of all landscaping within the highway boundary referenced to the landscaping details described in paragraph 4.3 (o).
- (c) **Road Profiles** to a scale 1:500 Horizontal 1:100 Vertical

- 4.3 cont.
- (d) **Surface Water Drainage Profiles** to a scale 1:500  
Horizontal 1:100 Vertical.
  - (e) **Typical Cross Sections** .
  - (f) **Section 79(1) Agreement** for any bridges or structures.
  - (g) **A Safety Audit** for the design should be included, where appropriate, in accordance with HD19/03.
  - (h) **Consultation Certificates** from appropriate bodies.
  - (i) **Site Investigation Information.**
  - (j) **Form RB1** if required.
  - (k) **Design and Check Certificates** see Appendix B.
  - (l) **General Arrangement Drawing of all Structures** showing the structural form, clear span(s) and other leading dimensions, headroom or clearance, materials, finishes and parapets with elevation, plan and typical cross sections to scales 1:50, 1:20, 1:10 as appropriate.
  - (m) **Cycling Audit.**
  - (n) **Access Statement** for the design in accordance with the procedure in Section 39 of this document.
  - (o) **Details of landscaping** within the highway boundary for the proposed development.
    - (i) Layout plan showing proposed landscaping including areas to be grassed and planting beds.
    - (ii) Planting schedule for all landscaping areas including seed mixes for grassed areas, species of plants and plant sizes proposed.

It will be acceptable for these documents to be submitted in an approved electronic format. The Local Roads Authority's Representative should be contacted to confirm details of acceptable electronic formats.

Drainage 

- 4.4 Design calculations, including check certificate, for the drainage system will be required to show the adequacy of both the system and the discharge points.

Drainage layouts and designs must be approved by Representatives of the Local Roads Authority and Scottish Water. Where connection of the road drainage to a public sewer is not permitted alternative arrangements for road drainage should be agreed with the Local Roads Authority, Scottish Water and the Scottish Environmental Protection Agency (SEPA).

Where connections are made to a private drainage system written confirmation is required to show that authority has been obtained from the appropriate proprietor, and other relevant agencies, such as SEPA.

A Consultation Certificate will be required indicating that Scottish Water and SEPA are in agreement with the proposed drainage layout.

Pipes and  
Culverts under  
Roads   
(span or diameter  
less than 1.5  
metres)

- 4.5 For pipes and culverts under roads a hydrological study of the catchment area along with a hydraulic design of the proposed pipe or culvert and outfall should be provided along with confirmation that this has been checked independently. Grills should be designed to facilitate ease of maintenance and prevent flooding and, where possible, grills should allow for overflow during flood conditions or where the grill face is blocked with debris.

Structures   
(including pipes  
and culverts with  
span or diameter  
greater than 1.5  
metres)

- 4.6 Where the submission includes structural design, the Developer must obtain technical approval of the structure(s) in accordance with BD2/05 “Technical Approval of Highway Structures”. The Local Roads Authority will be the Technical Approval Authority for any structure which is to be adopted. Where a structure is identified as required it is recommended that the Local Roads Authority’s Representative should be contacted at an early stage to agree the design parameters required. The certificates contained in Annex C to BD 2/05 must be submitted for all stages including construction.

If the need for additional or amended structures arises after the granting of Construction Consent, the Developer should seek approval in accordance with BD 2/05 before starting construction.

The standards to be used for design shall be those set out in the DMRB, unless otherwise agreed by the Technical Approval Authority. Where aspects of the design are not covered by the requirements of the DMRB, the Developer shall propose suitable standards as an alternative. The Developer should note in particular the requirements for aesthetic qualities (BA41/98) and durability standards (BD57/01 & BA57/01).

As-built records for structures shall be provided as described in BD62/07 as part of the application for the adoption of the structure. (See Section 6.3)

Safety Audit 

- 4.7 All roads, junctions, improvements by Developers will require to be audited for safety. A copy of the **Safety Audit** should be included with the Construction Consent application. All Safety Audits shall be carried out by an Aberdeenshire Council approved Safety Auditor in accordance with HD19/03. (See Section 38)

For all schemes a Stage 2 Safety Audit should be carried out and the results submitted. For certain schemes a Stage 3 Audit will also be required. Further guidance on this can be sought from the Local Roads Authority's Representative.

Under certain circumstances Aberdeenshire Council would be prepared to offer this service to Developers for the appropriate fee.

Responsibility for Design 







- 4.8 **The granting of Construction Consent does not imply that the Local Roads Authority accepts any responsibility for the accuracy or suitability of the design.**

Soil Report 

- 4.9 A soil report should be provided (at the time of application or prior to construction commencing) giving the C.B.R. test results of the sub-grade, for sub-base determination.

If the road construction is to be less than 450mm the soil report should include a certificate of non-frost susceptibility for the sub-grade.

The site investigation should also determine the suitability of the underlying soil for the chosen SUDS treatment methods and this should be considered in the submitted report.

- Mineral Report  4.10 In areas which are known to have been infilled or have a history of mineral workings the Local Roads Authority's Representative may require the developer seeking Construction Consent to supply a mineral report together with supporting information on ground stability.
- Docqueting of Plans  4.11 **It is essential the plans, detailed drawings and specification submitted with the application are docqueted, "This is the plan/drawing/specification referred to in the application", signed and dated by the applicant.**
- Notification of Owners  4.12 Where any person other than the developer owns land which fronts, abuts or is comprehended in **the new road(s) or the extension of the existing road(s)** for which Construction Consent is being sought, the developer will be required to declare on **Form CC2** (obtainable at the Transportation and Infrastructure offices or the Aberdeenshire Council Web Site) that all such persons have been notified of the application for Construction Consent. Copies of the notices serviced on Owners must be included.
- Owner's Objections  4.13 Any person to whom the applicant has been intimated under the provisions of the preceding paragraph may, within twenty-eight days of the date of intimation, make written representation to the Local Roads Authority. Any such representation will be considered before Construction Consent is granted.
- Hearing of Application  4.14 Should it be considered that the application for Construction Consent be refused or granted subject to special conditions, the applicant will be afforded an opportunity to be heard prior to such a decision being made.
- Construction Period  4.15 It will be a standard condition of any Construction Consent that the Construction will be completed within the period specified in the Consent. This period will not be less than three years and will be based on the Developer's proposed programme of works.
- If, as a result of a change in circumstances during construction, it is demonstrated that the specified period is no longer realistic, the Local Roads Authority may grant an extension.
- In normal circumstances, once homes are occupied, no more than one extension of time will be granted by the Local Roads Authority.**
- If the full development is not completed within the specified period, including any extension, the Developer will be required to amend the Construction Consent to allow adoption of that part which is open to public use.
- Alternatively, the roads will be completed by the Local Roads Authority using the Road Bond.

Issue B

Right of Appeal **A**

4.16 If an application for Construction Consent is (i) refused or (ii) granted subject to special conditions, the applicant may within twenty-eight days of the date of intimation of such a decision appeal to the Scottish Ministers.

Amendments to Consent **A**

4.17 Should the developer, for any reason, wish to depart from the construction or layout details for which Construction Consent has been granted, he must first seek the approval of the Local Roads Authority's Representative. Major changes may require the submission of a new application for Construction Consent.

Road Lighting **A**

4.18 The Developer should note that provision of road and footway lighting is made by the Developer and at his own expense, such provision to be to the specification of the Local Roads Authority – See Section 32. In the interest of public safety the Developer should provide operational street lighting adjacent to occupied housing.

Road Bond **A**





4.19 Where a developer is required to lodge a Road Bond or deposit (Section 3.8) **Form RB1** (obtainable at the Transportation and Infrastructure offices or the Aberdeenshire Council Web Site) should be completed as part of the application for Construction Consent.

**The Road Bond must be lodged with the Local Roads Authority before any house building can commence.**

An A4 size drawing shall be provided showing the Construction Consent area applied for outlined in red. The area for which a bond is required for any section within the Consent area is to be outlined in blue.

The Local Roads Authority's Representative shall determine the amount of bond "sufficient to meet the cost of completing the private road in accordance with the Construction Consent."

## 5. Inspection Procedures during Construction

- Notice of Commencement 
- 5.1 Two weeks written notice must be given to the Local Roads Authority's Representative of the start of roadworks together with names, telephone numbers and email addresses of responsible persons who may be contacted in connection with the construction of the works.
- Inspection and Testing 
- 5.2 During the construction period, irrespective of whether or not it is intended that the road(s) be subsequently adopted as public, the Local Roads Authority's Representative must be afforded access to the site to ensure that the works are being undertaken in conformity with the Construction Consent. The Developer and/or his contractor shall provide every facility to enable the Local Roads Authority's Representative to examine the works being executed and the materials being used, but the Developer shall remain responsible for ensuring that standards are met.
- In certain circumstances the Local Roads Authority's Representative may require samples of the various materials to be used together with particulars as to the source of supply or manufacture of such materials to allow further testing to be carried out. These samples will be provided free of cost by the Developer. The Developer will also bear the cost of any testing required.
- Certificates of Testing 
- 5.3 **The Developer will be responsible for providing test certificates for all materials used on site. Details of the applicable tests, frequency testing, etc. are outlined in the Specification, Appendix 1/5.**
- All testing is to be carried out by a laboratory carrying specific UKAS accreditation for the required tests.**
- Certificates of Inspection 
- 5.4 Notwithstanding any use the Developer may make of consulting engineers, and the submission of certificates of inspection from consulting engineers, the Local Roads Authority's Representative must be afforded access to the site in all cases to carry out inspections as deemed necessary by the Local Roads Authority's Representative, **and the Developer will be required to meet the cost of these inspections.**

Notice of Operations 

- 5.5 The Developer must give the Local Roads Authority's Representative a minimum of 48 hours written notice (excluding weekends) of the following operations:
- (a) Commencement of each of the pavement layers to the carriageways, footways, cycle tracks and footpaths;
  - (b) Each concrete pour (including blinding) and commencement of steel fixing where reinforced concrete is used;
  - (c) Setting out of road lighting plant positions, backfilling of cable trenches and painting of lighting columns;
  - (d) Approval of formations;
  - (e) Approval of foundations;
  - (f) Installation of bearings;
  - (g) Steelwork erection;
  - (h) Bridge deck waterproofing;
  - (i) Bridge deck expansion joints;
  - (j) Alignment of stringcourses or parapets.

If the works are suspended for any reason the Developer must comply with the above requirements prior to restarting on site.

It should be noted that these are minimum requirements and that, in certain cases, the Developer may be required to notify the Local Roads Authority's Representative of additional construction stages.

Inspection at Completion of Works 

- 5.6 Towards completion of any development incorporating new roads, a request should be made to the Local Roads Authority's Representative to have an inspection carried out. As a result of this inspection, a list of any remedial work required to bring the road(s) up to the Local Roads Authority standards will be prepared. Following the satisfactory completion of any such remedial work, an application may be made as detailed in Section 6.0 for the addition of the road(s) to the Local Authority's list of public roads.

It should be noted that where a Stage 3 Safety Audit has been required by the Local Roads Authority's Representative it must be carried out and the result submitted prior to the final inspection of the works.

Recovery of Expenses 

- 5.7 Attention is drawn to Section 140(6) of the Roads (Scotland) Act 1984 which entitles the Local Roads Authority to recover expenses reasonably incurred by them to ensure that the work carried out complies with the Construction Consent.**

**The recovery of these costs will be from the person to whom the Construction Consent was granted.**

**The Local Roads Authority gives notice of its intention to recover those expenses to which it is entitled under the Act.**

Reduction of  
Bond 

- 5.8 At pre-determined stages in the construction partial release of the bond, up to a maximum of 90%, may be permitted.

On completion of the carriageway binder course and kerb log to the satisfaction of the Local Roads Authority's Representative written application may be made for a reduction in Bond to 50% of its value.







On completion of the carriageway, footways and cycle tracks to adoptable standard, a written application may be made for a reduction in Bond to 10% of its value.

Health and  
Safety 

- 5.9 The Developer is advised of his responsibility under the Construction (Design and Management) Regulations 2007 (CDM). The Developer should be satisfied that he has appointed a competent CDM Co-ordinator, Designer and Principal Contractor.

The Local Roads Authority's Representative may require details of the appointed CDM Co-ordinator.

## 6. Application for Adoption of New Roads and Footpaths







- Application for Adoption 
- 6.1 Following completion of a private road constructed in accordance with a Construction Consent, a written application for its inclusion in the Local Roads Authority's list of public roads may be submitted to the appropriate Local Roads Authority's Representative by the person to whom such consent was granted.
- Footpaths 
- 6.2 Only those footpaths which have been agreed in accordance with paragraph 3.3 will be eligible for adoption.
- Documents to Accompany Application 
- 6.3 The submission should include copies of the drawings described in paragraph 4.3 and contain all relevant details **as built**, including those detailed in Section 4.6 for structures, where applicable. These drawings may be submitted as paper copies or electronic versions in a suitable CAD format. The roads, footways, cycle tracks and structures offered for adoption should be shown in colour, and the plans should clearly indicate the ownership of all areas so coloured. A 1/2500 scale drawing showing the development should be included.
- If a Stage 3 Safety Audit has been requested the results of this audit shall be provided along with the application.
- In addition the Developer will be required to provide a copy of the site Health and Safety File. This should include details of construction techniques used and maintenance requirements for any novel features included in the development, such as structures, SUD systems and the like. Further guidance can be sought on this topic from "Managing Health and Safety in Construction. Construction (Design and Management) Regulations 2007. Approved Code of Practice", published by the Health and Safety Executive.
- Adoption Inspection 
- 6.4 Within a period of twelve months from the time of application for adoption of a new road, an inspection will be undertaken by the Local Roads Authority's Representative to ensure that the road has not deteriorated to a standard below that required for adoption. Any defects will have to be made good to the satisfaction of the Local Roads Authority's Representative.
- Addition to List of Public Roads 
- 6.5 Following a satisfactory adoption inspection, recommendation will be made to the Local Roads Authority that the roads be added to the list of public roads, in terms of the Roads (Scotland) Act 1984, as appropriate.
- Release of Bond 
- 6.6 Following a satisfactory adoption inspection, which would allow the adoption of roads to proceed, a written application may be made for the remaining security or Bond to be returned.

## **Part 2 GEOMETRY AND LAYOUT**

### Preamble

This part of the document is intended to assist developers in the geometric design of road layouts and associated facilities. The following sections describe first how the guidelines should be used to conceive a layout in terms of road hierarchy and then give some detailed design guidance for each type of road for associated facilities.

## 7. Use of Guidelines for Layout Design

- Consultation  7.1 Whenever it is intended to construct a new road or extend existing roads, the desirability of consultation from the earliest stage cannot be over-emphasised.
- Guideline Principles  7.2 An understanding of the principles behind these guidelines is essential in their application to the geometric design of road layouts and the following paragraphs are included to brief developers in this respect.
- Road Layout  7.3 **It is not the intention to dictate road layout to the developer but rather to indicate how an overall design concept can be realised by different combinations or various types of road, always taking account of such factors as road safety, the environment and ease of maintenance.**
- Road Types  7.4 The type of road required for a particular situation is governed by its function and by the type and volume of traffic that will use it. Since, for access roads, traffic volume is directly related to the number and type of premises served, each element of a road system is defined in terms of the development, which takes access from it.
- Parking and Service Areas  7.5 Vehicles parked on the carriageway reduce both the safety and traffic capacity of a road and development design should therefore aim to minimise this practice. Guidance on achieving this objective is contained in Sections 25 and 26, but detailed advice regarding appropriate parking and servicing provision for a particular development should be sought from the Local Roads Authority's Representative. Off road parking areas in residential areas that are provided in lieu of garages or private driveways are not acceptable for adoption.
- Additional Design Consideration  7.6 A road layout should not be conceived in isolation but as an element in the overall design of a development. Developers should ascertain at an early stage the requirements of the Statutory Undertakers, Public Transport Unit and others concerned with servicing the development and make reference to the design notes contained in Sections 27 and 28.

The design should be consistent with any planning requirements, particularly if a development brief exists for the site. A good design should take account of the following aspects:

- i) Character of the site and surrounding area;
- ii) Existing topography;
- iii) Conservation status of the surrounding area;
- iv) Planning guidance within the Local Plan and its supplements.

Future  
Development 

7.7 **The developer must anticipate future extensions to the development since the level of access provided may limit the extent to which further development will be permitted. It should be noted that future development strategies are indicated in the Aberdeenshire Local Plan. Road types should therefore be related to the final volumes of traffic envisaged which will not necessarily be solely those generated by the initial development. A plan indicating possible future extensions should be prepared and submitted to the Local Roads Authority’s Representative.**

Infill  
Development 

7.8 In greenfield development the application for these guidelines is relatively straightforward, however the redevelopment of existing “built-up” areas and “infill” development is less so. While the basic principles outlined above are equally applicable to these latter sites, the constraints of adjacent developments and the prevailing conditions in the locality may give rise to complications in achieving the desired standards. It is therefore of paramount importance that the Local Roads Authority’s Representative is consulted at the earliest opportunity where infill development is contemplated, so that any difficulties in complying with these guidelines can be identified and alternative proposals evaluated. Cognisance should also be taken of the likelihood of further redevelopment or subsequent road improvements.

Rural Areas 

7.9 It should be noted that these guidelines refer essentially to urban areas. In rural areas, where higher vehicle speeds necessitate more stringent design criteria, reference should be made to the current Scottish Executive’s Design Manual for Roads and Bridges. Further guidance of rural development standards is given in Section 23.

Safety Audits 



7.10 Safety Audits will be required for all developments, except with express permission from the Local Roads Authority’s Representative. For all schemes a Stage 2 Safety Audit should be carried out and the results submitted. For certain schemes a Stage 3 Audit will also be required. Further guidance on this can be sought from the Local Roads Authority’s Representative. (See Section 38).

The Safety Audits must be carried out in accordance with HD19/03, by an Aberdeenshire Council approved auditor. The cost of such audits will be borne by the Developer.

Access  
Statements 

7.11 Access Statements will be required for all developments, except with express permission from the Local Roads Authority’s Representative. Further guidance on this can be sought from the Local Roads Authority’s Representative. (See Section 39).

## 8. The Road Network

- Function  8.1 The road network fulfils two main functions, namely; the movement of all forms of traffic from one location to another, and the provision of access to individual premises. Desirably, for reasons of safety and efficiency, no single length of road should fulfil both functions.
- Road Hierarchy  8.2 A stepped approach to road characteristics has therefore been defined in the form of a roads hierarchy as indicated in paragraph 8.3. Other combinations of hierarchy may be permissible for small gap sites at the discretion of the Local Roads Authority.
- All new roads will be designed and constructed in accordance with this hierarchy with consideration being given to the classification of existing roads. This hierarchy establishes the principle of access, designated design speed and the spacing and nature of junctions.
- Types of Road  8.3 In considering road infrastructure for new developments it is therefore first necessary to define each element of the road network (both existing and proposed) according to its principle function.
- (a) PRIMARY DISTRIBUTOR ROADS – provide for traffic movements into and out of a town and link major residential and commercial districts. The design of this category of road will normally be the responsibility of the Local Roads Authority;
  - (b) DISTRICT DISTRIBUTOR ROADS – provide for major traffic movements within a town or district. The design of this category of road will normally be the responsibility of the Local Roads Authority;
  - (c) LOCAL DISTRIBUTOR ROADS – distribute traffic within a district and link District Distributor Roads to Residential Roads;
  - (d) INDUSTRIAL ACCESS ROADS – link industrial/commercial premises and their associated parking areas to Local Distributor Roads.

(e) RESIDENTIAL ROADS – provide frontage access to properties within a residential area and link with Local Distributor Roads. All Residential Roads will be subject to a 20mph speed limit zone. They have been further categorised as follows:

(1) CORE ROADS – link residential premises and associated parking areas to Local Distributor Roads;

(2) HOUSING ROADS - link residential premises and associated parking areas to Local Distributor Roads either directly or via Core Roads;

(f) HOME ZONES – provide an alternative approach to providing access to residential properties

Infill  
Development 

8.4 In established built up areas, where redevelopment of a gap site is proposed, it may not be possible to provide the hierarchy defined in paragraph 8.3, especially where roads, which on account of their traffic volume should be classed as Distributors, already feature frontage access to dwellings. Guidance on individual cases should be sought from the Local Roads Authority’s Representative.

Figure 8.1: Sample Layout of General Access Roads and Culs-de-sac 

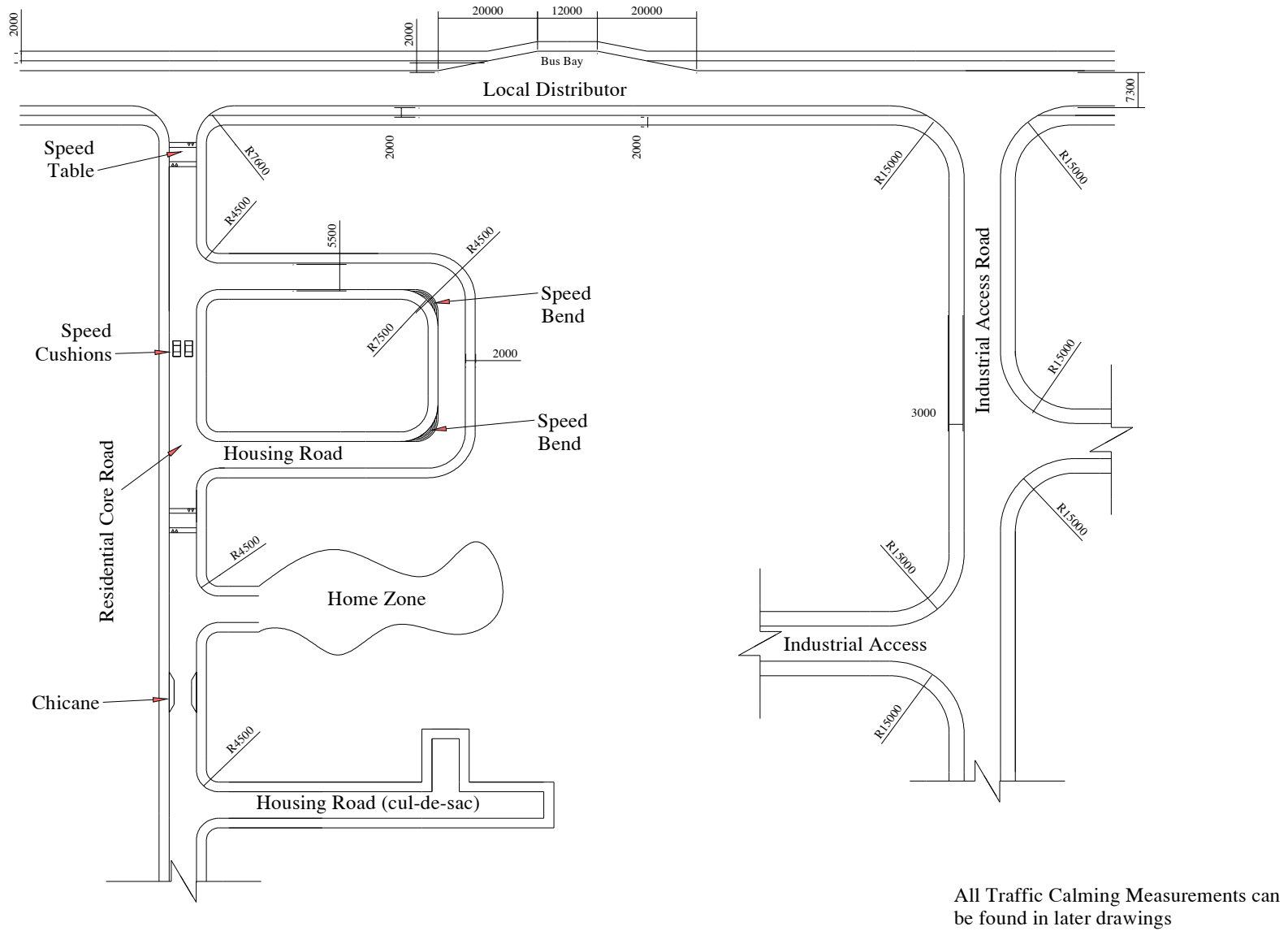

Figure 8.1: Sample Layout of General Access Roads and Culs-de-sac

## 9. Primary and District Distributor Roads

### Function

9.1 PRIMARY and DISTRICT DISTRIBUTOR ROADS provide a network of roads that provide for traffic movements that link major industrial and residential areas as well as providing for traffic movements into and out of a town. DISTRICT DISTRIBUTOR ROADS are the feeder roads for LOCAL DISTRIBUTOR ROADS and into the lower ends of the hierarchy.

### Layout

9.2 The layout of PRIMARY and DISTRICT DISTRIBUTOR ROADS should be designed to encourage the through movement of general traffic.

### Geometry

9.3 The standard width of carriageway shall be 7.3m and bus bays will be required at bus stops. The Local Roads Authority's Representative may require the inclusion of pedestrian refuges adjacent to bus bays. The design speed adopted will depend on the intended speed limit of the proposed road, but is likely to be at least 60kph. Consultation with the Local Roads Authority's Representative will be required to determine the intended speed limit for the proposed road.

When the speed limit for the proposed road has been set, Table 2 of TD 9/93 (DMRB 6.1.1) should be used to determine the appropriate design speed for the proposed road.

In circumstance where the proposed road is not considered to be an Urban Road then the design speed shall be determined in accordance with Chapter 1 of TD 9/93 (DMRB 6.1.1).

### Verges

9.4 A verge at least 2 metres wide shall be provided at all times on each side of the carriageway unless otherwise directed by the Local Roads Authority's Representative.

### Footways/ Cycletracks

9.5 The aim both in new development and in redevelopment should be to achieve a system whereby pedestrians and cyclists are segregated from vehicle movements. In most instances footways/cycletracks should be provided remotely from the PRIMARY or DISTRICT DISTRIBUTOR ROAD. Where footways/cycletracks do run alongside PRIMARY or DISTRICT DISTRIBUTORS they shall be at least 3 metres wide and shall be separated from the carriageway by a 2.0 metre verge.

It should be noted that combined footways/cycletracks will require to be the subject of a formal Traffic Order and signed in accordance the current version of The Traffic Signs Regulations and General Directions. The Developer will be liable for the costs associated with the required Traffic Order and route signage.

Pedestrian  
Crossing  
Facilities 

9.6 Normally where pedestrian movements are likely to be high and the relevant criteria can be met, facilities for pedestrians will be provided by means of controlled or grade separated crossings. However, in certain circumstances it may be more appropriate to reduce vehicle speeds to allow pedestrians to cross more safely. Details of appropriate traffic calming features are highlighted in Section 20.

Abnormal  
Loads 

9.7 The design of PRIMARY and DISTRICT DISTRIBUTOR ROADS must take account of the requirements for the movement of abnormal loads. Certain routes within Aberdeenshire Council are used to move abnormally large vehicles, and these routes have specific features to ensure that this can be done as easily as possible. Early consultation with the Local Roads Authority's Representative should be undertaken to determine if the proposed route is likely to be used for the movement of Abnormal Loads. If this is the case further guidance will be given as to specific features that shall be included in the overall design. This may include aspects such as demountable street furniture or additional clearance requirements to obstructions.

## 10. Local Distributor Roads

### Function

10.1 LOCAL DISTRIBUTOR ROADS distribute traffic within environmental areas and form the link between DISTRICT DISTRIBUTORS and RESIDENTIAL ROADS. They are also likely to be potential bus routes. LOCAL DISTRIBUTORS are traffic routes and not suitable for frontage development with direct access. Any road serving more than three hundred dwellings or serving both residential and industrial developments must be designed to at least LOCAL DISTRIBUTOR standards.

### Layout

10.2 The layout of LOCAL DISTRIBUTOR ROADS should be designed to discourage major through movement of general traffic.

### Geometry

10.3 The standard width of carriageway shall be 6.5 metres and bus bays may be required at stops. The Local Roads Authority's Representative may require the inclusion of pedestrian refuges adjacent to bus bays. Roads giving access to industrial development shall be at least 7.3 metres wide. A design speed of at least 60kph shall be adopted for determining road alignment in accordance with the national Design Manual for Roads and Bridges.

### Accesses

10.4 Individual frontage accesses to residential properties are not permitted from a Local Distributor Road. With the express permission of the Local Roads Authority it may be acceptable to form a footway crossing to serve a courtyard or the like.

A full standard junction may be formed to serve individual premises, such as a hotel, and should be designed in accordance with Section 18.

### Verges

10.5 A verge at least 2 metres wide shall be provided at all times on each side of the carriageway unless otherwise directed by the Local Roads Authority's Representative.





### Footways/ Cycletracks

10.6 The aim both in new development and in redevelopment should be to achieve a system whereby pedestrians and cyclists are segregated from vehicle movements. In most instances footways/cycletracks should be provided remotely from the Local Distributor Road. Where footways/cycletracks do run alongside LOCAL DISTRIBUTORS they shall be at least 3 metres wide and shall be separated from the carriageway by a 2.0 metre verge.





It should be noted that combined footways/cycletracks will require being the subject of a formal Traffic Order and signed in accordance the current version of The Traffic Signs Regulations and General Directions. The Developer will be liable for the costs associated with the required Traffic Order and route signage.

- 10.7 Normally where pedestrian movements are likely to be high and the relevant criteria can be met, facilities for pedestrians will be provided by means of controlled or grade separated crossings. However, in certain circumstances it may be more appropriate to reduce vehicle speeds to allow pedestrians to cross more safely. Details of appropriate traffic calming features are highlighted in Section 20.

## 11. Industrial Access Roads

- Function  11.1 INDUSTRIAL ACCESS ROADS provide frontage or service access to industrial and commercial premises.
- Layout  11.2 INDUSTRIAL ACCESS ROADS should preferably form a loop although a short cul-de-sac incorporating a turning circle or other approved turning facility (Section 19) may be considered.
- Geometry  11.3 INDUSTRIAL ACCESS ROADS are transitional in nature between full standard distributor roads and the local industrial/commercial environment and may therefore be constructed to reduced standards of alignment compared with Distributor Roads. This will largely depend upon the length of the roads and it is still desirable to use a formal design speed for assessing curve radii and visibility.
- Footways/  
Cycletrack  11.4 A shared footway/cycletrack at least 3 metres wide (2.5m in limited situations) shall be provided on each side of the carriageway (Section 22). However, if development is to one side of the road only, the requirement for a footway/cycletrack on the opposite side of the road may be relaxed.
- It should be noted that combined footways/cycletracks will require being the subject of a formal Traffic Order and signed in accordance the current version of The Traffic Signs Regulations and General Directions. The Developer will be liable for the costs associated with the required Traffic Order and route signage.
- Verges  11.5 Wherever a footway/cycletrack is not provided adjacent to the carriageway, a 2 metres wide grass verge will be required between edge of carriageway and any fence, boundary wall, hedge, etc.

## 12. Core Roads

- Function  12.1 A CORE ROAD may function as a collector road linking a LOCAL DISTRIBUTOR ROAD to a number of HOUSING ROADS and/or HOME ZONES. It may act as a housing road in its own right with frontage access to dwellings. No more than three hundred dwellings in total may be served by a CORE ROAD.
- Where a CORE ROAD is not a loop and serves more than 50 but less than 100 dwellings, an emergency access route must be provided.
- Where a CORE ROAD serves in excess of 100 houses it MUST have TWO points of access.
- Layout  12.2 CORE ROADS should be laid out to discourage through traffic movements and be of loop form where possible. Where a cul-de-sac greater than 110m long is permitted it should incorporate a tuning circle.
- Geometry  12.3 CORE ROADS are transitional in nature between full standard Distributor Roads and the local domestic environment and may therefore be constructed to reduced standards of alignment compared with Distributor Roads. This will largely depend upon the length of the roads, and it is still desirable to use a formal design speed for assessing curve radii and visibility.
- Footways  12.4 A footway of at least 2.0 metres wide (Section 15) shall be provided on each side of the carriageway. However, if development is to one side of the road only, the requirement for a footway on the opposite side of the road may be relaxed. Only where there is a segregated footpath system, and it can be demonstrated that pedestrians are unlikely to walk along the access road, may the requirements for any footway be waived.
- Verges  12.5 A 2 metre wide verge will be required whenever a footway is not provided.

Bus Route  
Provision **A**

- 12.6 To ensure that the development can be serviced effectively by Public Transport certain Core Roads will require to be designed to a higher standard, to allow them to serve as Bus Routes. At the design stage the requirements of the Public Transport Operators may not have been determined.

To allow for future implementation of a Public Transport regime, carriageways to Bus Route standard must be provided to ensure that no dwelling is more than 400 metres, by the shortest designated pedestrian route, from a potential Bus Route. Further guidance on this matter may be sought from the Local Roads Authority's Representative.

Parking **A**

- 12.7 The overall layout of a CORE ROAD should be such as to discourage parking on footways. This practice is illegal and presents particular hazards to pedestrians, especially those in the most vulnerable groups.

## 13. Housing Roads

### Function

13.1 HOUSING ROADS give access to dwellings and therefore provide the links between these dwellings and LOCAL DISTRIBUTOR ROADS either directly or via CORE ROADS.

### Layout

13.2 HOUSING ROADS can be laid out in any form, taking access from the CORE ROAD and from each other as either loops, links or culs-de-sac. Their layout should be convenient and accessible for the driver without creating long lengths, or areas which can only be reached by a long and torturous route.

HOUSING ROADS can serve up to 50 properties.

### Geometry

13.3 At this level of the road hierarchy formal design speeds are inappropriate but, in the interest of the local residential environment, vehicle speeds should be restricted by the use of appropriate geometry and/or traffic calming features to ensure that the 20mph speed limit zone is self-enforcing.

### Parking

13.4 The overall layout of a HOUSING ROAD should be such as to discourage parking on footways. This practice is illegal and presents particular hazards to pedestrians, especially those in the most vulnerable groups.

## 14. Home Zones

### Function

- 14.1 Home Zones are residential streets in which the road space is shared between drivers of motor vehicles and other road users, with the wider needs of residents (including people who walk and cycle, and children) in mind. The aim is to change the way that streets are used and to improve the quality of life in residential streets by making them places for people, not just for traffic. Changes to the layout of the street should emphasise this change of use, so that motorists perceive that they should give informal priority to other road users.

A normal Home Zone will include a combination of the following features:

- a) A shared surface
- b) Indirect traffic routes
- c) Areas of planting
- d) User friendly street furniture, i.e. seats or play equipment
- e) Entrance/Exit Gateways
- f) Appropriate signage and lighting.

The key aim to be achieved by the creation of a Home Zone is to turn a residential street into a valued space, not just a place for movement.

It should be noted that a Home Zone is NOT suitable for through traffic. The design of a Home Zone should actively discourage through traffic.

### Legal Framework

- 14.2 The Local Roads Authority may designate any road for which they are traffic authority as a Home Zone under powers granted in the Transport (Scotland) Act 2001 and The Home Zones (Scotland) (No 2) Regulations 2002.

The Developer will be required to pay the costs of the legal processes involved in establishing a Home Zone.

At the start and end of any Home Zone signing in accordance with the current version of the Traffic Signs Regulations and General Directions will be required.

- 14.3 Home Zones should be integrated within the wider area, so that they are permeable and accessible to pedestrians, cyclists and local traffic. There should be a continuous network of routes for pedestrians and cyclists linking the Home Zone area with schools, public transport stops, green spaces and other services.

In general terms Home Zones should be set out to ensure that vehicles should not have to travel more than 400 metres along a Home Zone street. This distance should be measured from any point within the Home Zone to the nearest conventional street.

Ideally a pedestrian should not have to walk more than 400 metres, about 5 minute walk, to reach the nearest bus stop. The provision of bus services will be outwith the control of the Developer and the Local Roads Authority's Representative should be contacted at an early stage to discuss this particular requirement.

The number of houses served by a Home Zone should be around 20. However more properties could be served by subdividing the area into a number of zones linked to each other by conventional housing roads.

A Home Zone can take the form of streets, squares, courtyards or culs-de-sac. It is the buildings, trees, planting and surface treatments that should define the Home Zone's spaces, rather than conventional kerb edges and carriageway widths. No minimum width is specified for use by vehicles. The overall design of the Home Zone should be checked using a swept path analysis to determine the width required for vehicles to negotiate the layout. Careful consideration must be given to access by Emergency and Service vehicles, although the overall design concept must not be compromised. The use of removable obstructions may be one option to accommodate these types of access requirements.

Each Home Zone should be unique, depending on the building heights, setbacks, its overall architectural character and the community's use of the street. It is unlikely that all this can be achieved within an overall width of less than 8 metres. Designs must incorporate sufficient space for vehicles, pedestrians, cyclists, services, and leisure activities to coexist.

Further guidance can be sought from the Institute of Highway Incorporated Engineers document "Home Zones – Design Guidelines" June 2002, and the Scottish Executive document "Home Zone Guidance Consultation" 2002

Gateways 

14.4 It is important that vehicle drivers are aware that they are entering the Home Zone area. This can be achieved by the construction of a gateway feature at the entrance to the Home Zone. Further reference should be made to the Traffic Calming section of this guide.

Cross Corner  
Visibility 

14.5 The minimum cross corner visibility for drivers joining a Home Zone should be 9 metres corresponding to an inner kerb radius of 4.5 metres (see paragraph 18.10)

Statutory  
Undertakers 

14.6 Within new built HOME ZONES, there is the opportunity to plan the location of utilities so as they do not conflict with other elements of the HOME ZONE environment. Close liaison with the Utility companies will be required throughout the design and implementation stages.

Future  
Maintenance 

14.7 The Developer will be required to demonstrate that the whole life cost of the proposal, particularly in relation to bespoke items, has been fully considered in the design process.

At the design stage close liaison with Landscape Services and the Local Roads Authority's Representative will be required to ensure that potential problems with long term maintenance are avoided.

## 15. Design Criteria

Table 15.1 – Design Criteria for Primary and District Distributor Roads **A**

<b><u>Feature</u></b>	<b><u>Standard</u></b>	<b><u>Comment</u></b>
Design Speed	DMRB	Consultation with the Local Roads Authority's Representative will be required to set speed limit.
Carriageway Width	7.3m	See Section 17 for widening on curves.
Minimum Camber/Crossfall	2.5%	
Maximum Gradient	DMRB	
Minimum Gradient	0.8%	Minimum practical from drainage channels.
Minimum Vertical Curve Length	DMRB	Desirable Minimum.
Minimum Horizontal Curve Radius	DMRB	Desirable Minimum.
Minimum Sight Distance	DMRB	Desirable Minimum.
Verges	2m grass	
Footways/Cycletrack	3m footway/cycletrack	Required on both sides. May be relaxed to one side in certain circumstances.

Table 15.2 – Design Criteria for Local Distributor Road 

<u>Feature</u>	<u>Standard</u>	<u>Comment</u>
Design Speed	60Bkph	Limited frontage access permitted.
Carriageway Width	6.5m	See Section 17 for widening on curves.
	7.3m	For roads serving industrial areas.
Minimum Camber/Crossfall	2.5%	
Maximum Gradient	5.5%	On difficult sites steeper gradients may be permitted over short lengths at the discretion of the Local Roads Authority's Representative.
Minimum Gradient	0.8%	Minimum practical from drainage channels.
Minimum Vertical Curve Length	K x algebraic difference in % gradient	Where K = 17 (crests) Where K = 13 (sags)
Minimum Horizontal Curve Radius	360m (3.5% superelevation) 255m (5.0% superelevation)	Desirable minimum; may be reduced on difficult sites (see SE's Design Manual for Roads and Bridges).
Minimum Sight Distance	90m	Desirable minimum; absolute minimum = 70m essential in all cases.
Verges	2m grass	
Footways/Cycletrack	3m footway/cycletrack	Required on both sides. May be relaxed to one side in certain circumstances.

Table 15.3 – Design Criteria for Industrial Access Road **A**

<b><u>Feature</u></b>	<b><u>Standard</u></b>	<b><u>Comment</u></b>
Design Speed	50kph	
Carriageway Width	7.3m	See Section 17 for widening on curves.
Minimum Camber/Crossfall	2.5%	Adverse camber to be removed.
Maximum Gradient	5.5%	May be increased over short lengths at the discretion of the Local Roads Authority's Representative.
Minimum Gradient	0.8%  1.25%	Minimum practical from drainage channels.  Where precast concrete block paving is to be used.
Minimum Vertical Curve Length	$K \times \text{algebraic difference in \% gradient}$	Where $K = 6$ (Crest) $K = 9$ (sag); absolute minimum length = 20m.
Minimum Horizontal Curve Radius	255m (3.5% superelevation) 180m (5% superelevation)	
Minimum Sight Distance	70m	
Verges	2m grass	Essential where there are no footways.
Footways/Cycletracks	3m footway/cycle track	Required on both sides. May be relaxed to one side in certain circumstances.

Table 15.4 – Design Criteria for Core Road **A**

<b><u>Feature</u></b>	<b><u>Standard</u></b>	<b><u>Comment</u></b>
Design Speed	30kph	Design must include features to ensure that 20mph speed limit is self-enforcing.
Carriageway Width	5.5m 6.0m	Bus routes.
Minimum Camber/Crossfall	2.5%	
Maximum Gradient	5.5%	May be increased over short lengths at the discretion of the Local Roads Authority's Representative.
Minimum Gradient	0.8%	Minimum practical from drainage channels.
Minimum Vertical Curve Length	$K \times$ algebraic difference in % gradient	Where $K = 6$ ; absolute minimum length = 20m.
Minimum Horizontal Curve Radius	20m	Except for speed control bends. Superelevation not essential.
Minimum Sight Distance	35m	Further reduction may be allowable if it can be determined that speeds will be lower. Refer to DB32.
Max spacing of traffic calming events	100m	To comply with 20mph Zones regulations.
Verges	2m grass	Essential where there are no footways.
Footways	2m footway	Required on both sides of the road.







Table 15.5 – Design Criteria for Housing Road **A**

<b><u>Feature</u></b>	<b><u>Standard</u></b>	<b><u>Comment</u></b>
Design Speed	30 kph	Design must include features to ensure that 20mph speed limit is self-enforcing.
Carriageway Width	5.5m	
Minimum Camber/Crossfall	2.5%	
Maximum Gradient	5.5%	May be increased over short lengths at the discretion of the Local Roads Authority's Representative.
Minimum Gradient	0.8%	Minimum practical from drainage channels.
Minimum Vertical Curve Length	$K \times \text{algebraic difference in \% gradient}$	Where $K = 3$ ; absolute minimum length = 15m.
Minimum Horizontal Curve Radius	15	Except speed control bends. Superelevation not essential.
Minimum Sight Distance	35m	Further reduction may be allowable if it can be determined that speeds will be lower. Refer to DB32.
Verges	2m	
Footways	2m footway	Required on both sides of the road.
Traffic Calming	Traffic calming feature every 100m	To meet requirements for 20mph Zone.

Table 15.6 – Design Criteria for Home Zones 

<u>Feature</u>	<u>Standard</u>	<u>Comment</u>
Design Speed		Design should encourage speed below 10-15kph.
Carriageway Width	3.0 metre “vehicle path” with 4.5m wide passing areas every 40 metres	It is unlikely that this can be achieved within an overall width of less than 8 metres. Design must incorporate sufficient space for vehicles, pedestrians, cyclists, services, and leisure activities to coexist.
Minimum Camber/Crossfall	2.5%	
Maximum Gradient	5.5%	May be increased over short lengths at the discretion of the Local Roads Authority’s Representative.
Minimum Gradient	0.8%  1.25%	Minimum practical from drainage channels.  Where precast concrete block paving is to be used.
Minimum Vertical Curve Length	$K \times \text{algebraic difference in \% gradient}$	Where $K = 2$ ; absolute minimum length = 10m.
Minimum Horizontal Curve Radius	No minimum.	Swept path analysis required.
Minimum Sight Distance	15m	Further reduction may be allowable if it can be determined that speeds will be lower. Refer to DB32.
Pedestrian Routes	2m	1.8m minimum.
Max spacing between traffic calming events	30m	
Max Length	400m	

## 16. Forward Visibility

- Standards**  16.1 The requirements for forward visibility for each type of road classification are set out in Sections 14 and 15.
- Measurement**  16.2 To enable drivers to see a potential hazard in time to slow down or stop comfortably it is necessary to consider the driver’s line of vision, in both the horizontal and vertical planes, and the stopping distance of the vehicle.
- Driver’s Eye Level**  16.3 The eye level of a driver can vary from 1.05m above the carriageway in a standard car to approximately 2.0m in commercial vehicles. To enable drivers to see each other across summits, across bends and at junctions, unobstructed visibility will be required at least between these heights above the carriageway.
- Target Height**  16.4 For drivers to see and be seen by pedestrians, particularly children and wheelchair users, unobstructed visibility will be required to a point closer to the ground. As there is a high likelihood of children in residential areas this lower limit should be set at 260mm.
- Obstructions to Visibility**  16.5 The most obvious obstructions to visibility are summits, adjacent buildings, walls, dense trees, and parked cars. It is important that any planting regime is determined taking account of the impact of future growth on visibility. Generally the aim should be to ensure good visibility without the need for future maintenance.
- Stopping Sight Distance**  16.6 The horizontal distance over which unobstructed visibility should be maintained will depend on the stopping distance of the vehicles. This in turn will depend upon vehicle speeds, deceleration rates and drivers reaction times. The requirements for each type of road are given in Sections 14 and 15.

However as general guidance the table below outlines stopping distances for various traffic speeds:

Table 16.1 - Stopping Sight Distance

Speed	0	5	10	15	20	25	30	Mph
	0	8	16	24	32	40	48	Km/h
Stopping Distance	0	6	14	23	33	45	60	M

## 17. Carriageway Widening on Curves



- Need for Widening**  17.1 The need for widening on curves depends upon the radius and the length of the curve, and the type of vehicles using the road. Table 17.1 shows the increased widths required on various bends to allow two vehicles to pass, while maintaining appropriate clearances.
- Residential Roads**  17.2 **RESIDENTIAL ROADS**, having a basic width of 5.5 metres need not be widened on curves of radii greater than 15 metres. A 5.5 metre width should still suffice provided the deflection is no more than 45°.
- Method of Widening**  17.3 Widening is most simply achieved by maintaining the outer kerb as a circular arc ( $R_o = \text{centreline radius} + 0.5 \text{ normal road width}$ ), and increasing the road width on the inside of the bend. Further details of inside kerb lines for industrial roads are to be found in “Designing for Deliveries” published by the Freight Transport Association.

Table 17.1 – Carriageway Widening on Curves

Centre Line Curve Radius (metres)	Road Width Required at Apex of 90° Bend (Metres)				
	Local Distributor Road		Industrial Access Road	Core Road	
	(6.5m basic)	(6.5m basic)	(7.3m basic)	(5.5m basic)	(6.0m basic)
25	-	-	-	7.3	7.8
50	-	-	9.4	6.8	7.3
75	-	-	8.7	6.3	6.8
150	6.9	6.9	7.9	5.9	6.4
300	6.5	6.5	7.3	5.5	6.0

## 18. Road Junctions







- Form of Junction  18.1 Where two roads intersect a right angled T-junction shall be formed with the major road, defined as that carrying the greater volume of traffic, continuous through the junction (Fig. 18.1).
- Priority  18.2 In general the geometric layout shall clearly establish the priority of the major road to approaching drivers. The Local Roads Authority's Representative may additionally require road signs and/or road markings to be provided, at the Developer's expense, to emphasise this priority.
- Sitting  18.3 It is preferable to site junctions on level ground or in sags rather than at, or near crests of hills. Where possible T-junctions on curves should be sited so that the minor road is on the outside of the curve. Junctions on the inside of sharp curves are most undesirable.
- Staggered Junctions  18.4 Where two minor roads approach a major road from opposite sides, a staggered junction comprising two T's should normally be used instead of a crossroads. Right/Left staggers (where the minor road traffic crossing the major road first turns right out of the minor road, proceeds along the major road and then turns left) are preferred to left/right staggers.
- Geometry  18.5 Road junctions should be designed to meet the criteria listed in Table 18.1, and laid out as illustrated in Figure 18.1.
- Spacing  18.6 Junction spacing (Table 18.1) is related to the likely volumes and speeds of traffic and to the distance required by moving vehicles to take up position between junctions for particular movements. The need to maintain road safety and minimise the likelihood of congestion will dictate the spacing and location of major access points.
- Major Road Visibility  18.7 Drivers approaching a major/minor priority junction along the major road shall be able to see the minor road entry from a distance corresponding to the Desirable Minimum Stopping Sight Distance applicable to the major road. These distances are detailed in Section 15.

Table 18.1 – Dimensions for Priority Junctions **A**

Major Road Type	Minor Road Type	Minimum Spacing on Major Road (metres)	Visibility Splay		Corner Radii R (metres)
			X (metres)	Y (metres)	
Unrestricted	Any	210	9.0	215	10.7
District Distributor	Local Distributor	210 (150**)	9 (4.5**)	120	10.7
Local Distributor (40mph)	Local Distributor	100	9 (4.5**)	120	10.7
Local Distributor	Local Distributor	100	9 (4.5**)	90	10.7
Local Distributor	Industrial Access Road	100 (40**)	2.4	59	15
Local Distributor	Core Road	100 (40**)	2.4	59	7.6
Industrial Access Road	Industrial Access Road	40	2.4	43	15
Core Road	Core Road	25	2.4	25	6
Core Road	Housing Road	25	2.4	25	4.5
Housing Road	Housing Road	25	2.4	25	4.5
Core Road	Home Zone	25	2.4	25	4.5
Housing Road	Home Zone	25	2.4 (2**)	25	4.5
Core Road	Car Park	25	2.4 (2**)	25	4.5

\*\*Absolute Minimum at the discretion of the Local Roads Authority's Representative

### Minor Road Visibility **A**

- 18.8 The principle of providing the required visibility for drivers approaching the junction on the minor road has three distinct features
- a) Approaching drivers shall have unobstructed visibility of the junction from a distance corresponding to the SSD applicable to the minor road. These distances are detailed in Section 15.
  - b) From a point 15 metres back along the centreline of the minor road, measured from the continuation of the line of the nearside edge of the running carriageway of the major road, an approaching driver shall be able to see clearly the junction form. This provides the driver with an idea of the junction form, possible movements and conflicts, and possible action required before reaching the major road.
  - c) Visibility splay requirements, detailed in Section 18.9

Visibility Splay **A**

18.9 At priority junctions there shall be full visibility to left and to the right. A visibility envelope from a viewpoint between 2.0 metres and 1.05 metres above carriageway level to an object point between 2.0 metres and 0.26 metres above the carriageway level across the visibility splay must be provided. It is imperative that the visibility is checked in both the horizontal and vertical planes. Account should be taken of any planting regime, including grass, and the likely maintenance that will be undertaken. Visibility criteria should be met with the minimum of future maintenance to any planting regime.

The X and Y distances (Table 18.1) are determined solely by the major road type and will be applied on this basis to junctions comprising combinations of road types not specifically listed in the table. Where, of necessity, a minor road forms an uphill approach to the major road, care should be taken to ensure that objects within the visibility triangle, do not interfere with visibility. For junctions on curves, reference should be made to the national Design Manual for Roads and Bridges for determination of parameters X and Y.

Cross Corner Visibility **A**

18.10 On roads with speed limits greater than 30 mph, cross corner visibility must be allowed for vehicles turning left into the non-priority road by providing a visibility radius tangential to the kerb (Figure 18.1). Typical visibility radii (m) are shown below:

Table 18.2 – Cross Corner Visibility Requirements

Inner Kerb Radius (m)	Visibility Radius
4.5	9
6.0	10
7.6	12
10.7	20

Special Cases **A**

18.11 In special cases (e.g. one-way roads) some reduction in the design speed may be permitted by express permission of the Local Roads Authority’s Representative. This may require the Developer to provide evidence of lower than assumed 85% speeds. Reductions in design speed will reduce the requirements for the junction.

Gradients **A**

18.12 The maximum gradient of the final approach of the minor road at junctions should be limited over the X distance to 2 percent where the major road is a DISTRICT or LOCAL DISTRIBUTOR. In other circumstances the gradient should be limited to 4 percent over a minimum distance of 8 metres.

Frontage  
Access/Parking  
A

18.13 No frontage access or lay-by parking will normally be permitted in the immediate vicinity of a road junction, or where parked vehicles would interfere with junction sightlines.

Dropped  
Kerbs A

18.14 Provision should be made at all road junctions for pedestrians to continue along the major road with a minimum of inconvenience. Kerbs must therefore be dropped as indicated in Figure 18.2, at all junctions other than those at which a footbridge or underpass, suitable for use by pedestrians with prams and wheelchairs, is provided. It should be noted that if the main road is classified as a Distributor Road, or higher, tactile paving **MUST** be installed at these dropped kerbs in accordance with the Department for Transport's Guidance on the Use of Tactile Paving Surfaces.

Unrestricted  
Major Road A

18.15 Where any minor road connects to a road, proposed or existing, that has an unrestricted speed limit the design of the junction will comply in every respect with the standards set out in the current version of the Design Manual for Roads and Bridges.

Additional  
Requirements for  
Home Zones A

18.16 Home Zones must be clearly marked at their entrances and exits to ensure that all street users recognise the different nature of the area. The Home Zone sign should be used to provide a clear statement to drivers of the change in operation of the streets. The use of this sign must be supported by the legal designation of the area as a Home Zone under the appropriate legislation; and the completion of the necessary physical measures.

In addition to signage a visual statement should be created at the entrance to a Home Zone. At the simplest this "gateway" may just be a change of surface material or colour, but in most cases more substantial features will be required. One option would be to create the junction in the form of a footway crossing, thereby giving priority to pedestrians, another option would be to create a raised junction, see Figure 18.3.

Care should be taken to ensure that the visually impaired are aware of the change in nature of the road. This can be achieved by the use of tactile paving, possibly the corduroy pattern. Further details on the use of this material can be found in Department for Transport's Guidance on the Use of Tactile Paving Surfaces.

Further guidance on all these aspects can be sought from the Institute of Highway Incorporated Engineer's Home Zones – Design Guidelines, The Scottish Executive's Home Zones – Guidance Consultation, and the Local Roads Authority's Representative.

Junction  
Markings 

- 18.17 Junction markings will be required at most junctions. Where any road joins a Distributor, or higher, classified road junction marking and signage shown on Figure 18.4 will be required.

If the junction is with a Core Road the junction markings shown in Figure 18.5 will be required. In certain circumstances this requirement may be relaxed at the discretion of the Local Roads Authority's Representative.

In general no junction markings will be required when both roads are Housing Roads classification or less.

Further guidance on road markings can be found in Section 28 of this guide.

Roundabouts 

- 18.18 Normal or Compact Roundabouts complying with the requirements of TD 16/07, contained in the Design Manual for Roads and Bridges, as amended in this document, shall be provided for any junction determined as requiring the provision of a roundabout.

Mini-Roundabouts to TD 54/07 shall not be permitted for new construction.

Overrun areas shall not be permitted. (See amendments to TD 16/07 below)

Roundabouts shall comply with the version of TD 16/07 (Geometric Design of Roundabouts) current at the date of application and amended as follows:-

- (a) *Paragraphs 7.17 and 7.18 are deleted.*
- (b) *Paragraph 7.63 is amended and shall become mandatory as Paragraph 1.9 of TD 16/07. Replace the second sentence "Normally the width would reduce at a taper of 1:15 to 1:20." with "The width shall reduce at a taper of 1:15 to 1:20."*
- (c) *The following additional paragraphs shall be added to TD 16/07 and shall be mandatory as Paragraph 1.9 of TD 16/07.*

**Vehicle Swept Paths**

*7.74 All Vehicle paths referred to in TD 16/07 shall be assessed for the range of vehicles and vehicle speed applicable to the class of road entering the roundabout as detailed in Figure 7/20 below.*

- 7.75 *Assessment shall be carried out using the Autotrack software produced by AutoDesk, or approved equivalent, and drawings provided showing the swept paths for the range of vehicles and speeds in Figure 7/20.*
- 7.76 *Where there is a requirement for the roundabout to accommodate particular types or sizes of vehicles, other than the specified design vehicles, the dimensions, required speeds and clearances will be specified for the vehicle. This requirement will apply to designated abnormal load routes or other roads as may be identified by the Roads Authority.*
- 7.77 *Swept paths shall demonstrate that vehicles can negotiate the roundabout while maintaining the minimum clearances from kerb lines and street furniture specified in Figure 7/20.*
- 7.78 *In areas of potential conflict between vehicles the swept paths shall demonstrate that the minimum clearances required can be achieved between both moving and stationary traffic.*
- 7.79 *The extent of stationary traffic queues for this assessment shall be the agreed peak flows from the traffic assessment for the junction.*

#### **Positioning of Utility Plant**

- 7.80 *Utility or drainage chambers, other than gullies, shall be located outwith the carriageway in entries, exits and the circulatory carriageway. Gullies shall, as far as possible, be located outwith the predicted path of cyclists and motorcyclists using the roundabout.*
- 7.81 *Utility plant, chambers, signs, lighting and electrical equipment shall be located so as to enable access for all routine maintenance operations, in compliance with the requirements of Chapter 8 of the Traffic Signs Manual, to be achieved while maintaining the operation of the roundabout without additional traffic control. This shall include maintaining pedestrian and cycle routes through the roundabout.*

#### **Landscaping**

- 7.82 *Landscaping shall be designed such that all maintenance can be carried out, in compliance with Chapter 8 of the Traffic Signs Manual, without requirement for traffic management or restriction of carriageway width. (See Paragraph 8.37 of TD 16/07)*

7.83 No areas of soft landscaping shall be permitted within 1m of any kerb line.

7.84 Landscaping design shall be such as to preserve all required sightlines with minimum future maintenance. (See paragraphs 8.38 – 8.42 of TD 16/07)

Figure 7/20: Swept Path Speeds and Required Clearances

	Speed Limit for Entry <i>(mph)</i>	Vehicle speed for Autotrack analysis <i>(kph)</i>	Minimum clearance from Kerb Line to wheels <i>(metres)</i>	Minimum clearance from all Street Furniture to body <i>(metres)</i>	Minimum clearance between vehicles travelling in opposite directions –mirror to mirror <i>(metres)</i>
<i>Large Car</i>	> 40	50	1.0	1.5	1.0
	40	40			
	30	30			
	≤ 20	20			
<i>Design Articulated Lorry as paragraph 7.15 of TD 16/07</i>	> 40	40	0.7	1.5	1.0
	40	30			
	30	20			
	≤ 20	15			
<i>Design Rigid Lorry</i>	≤ 20	15			

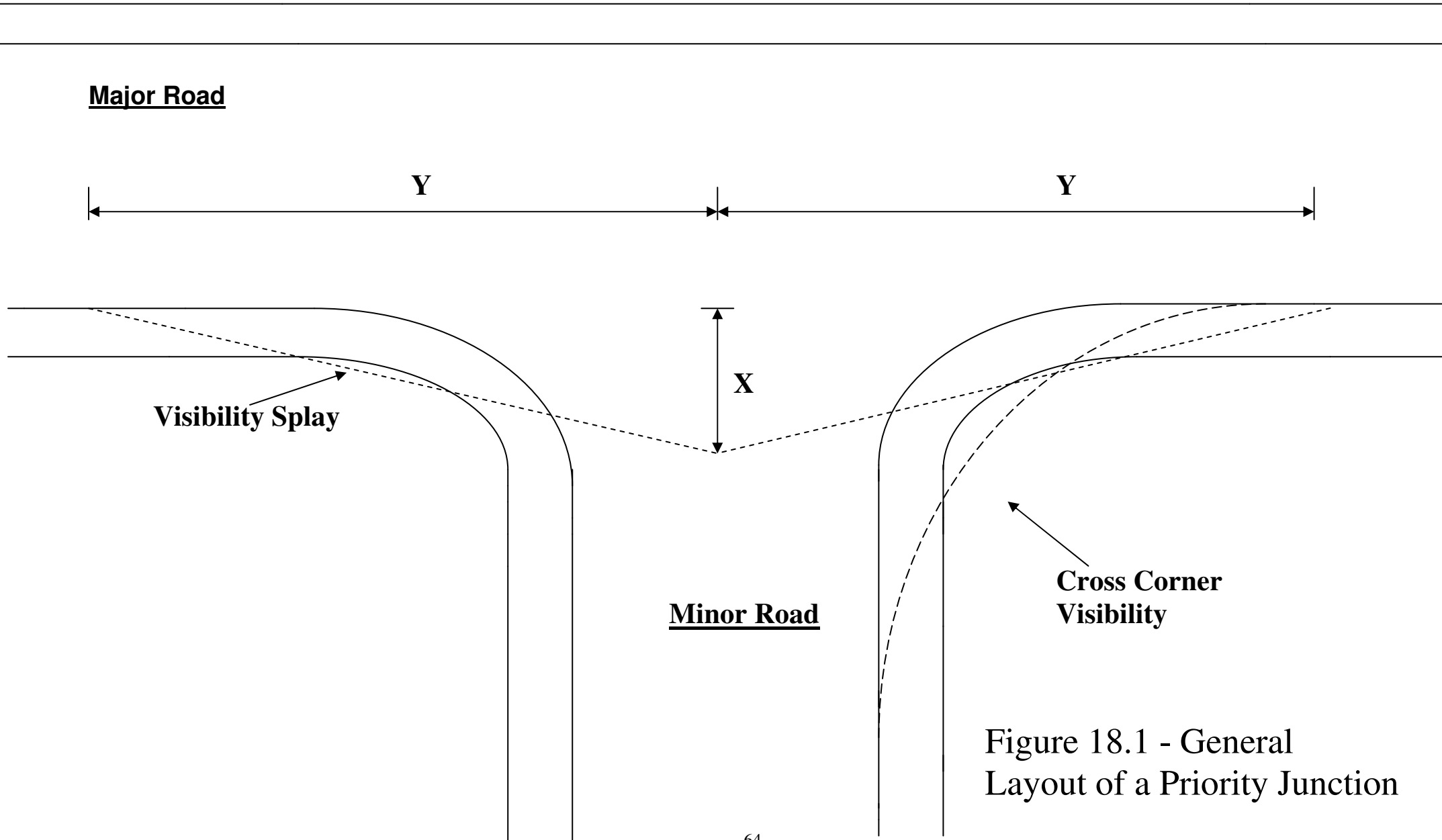

Figure 18.1 - General Layout of a Priority Junction

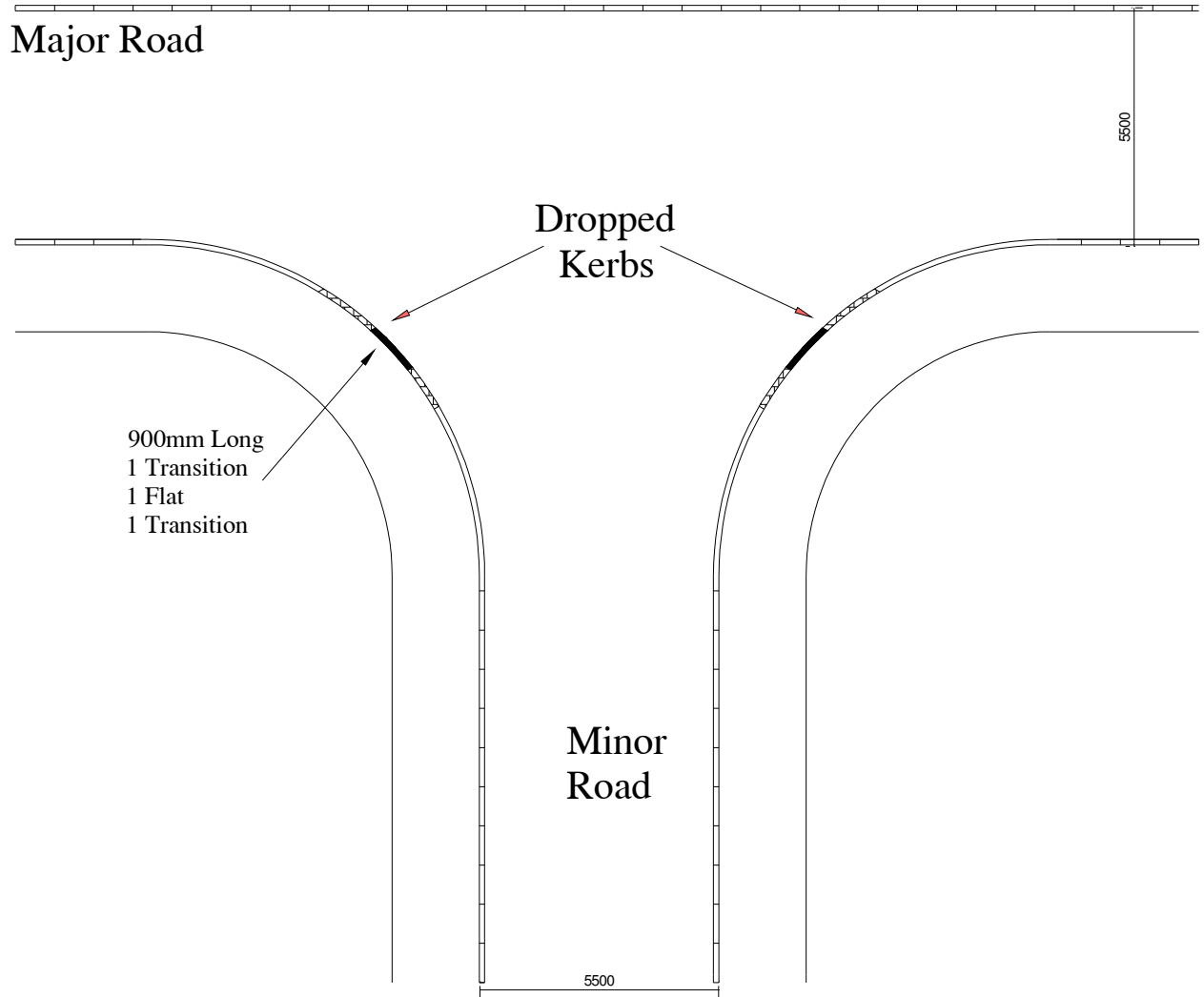
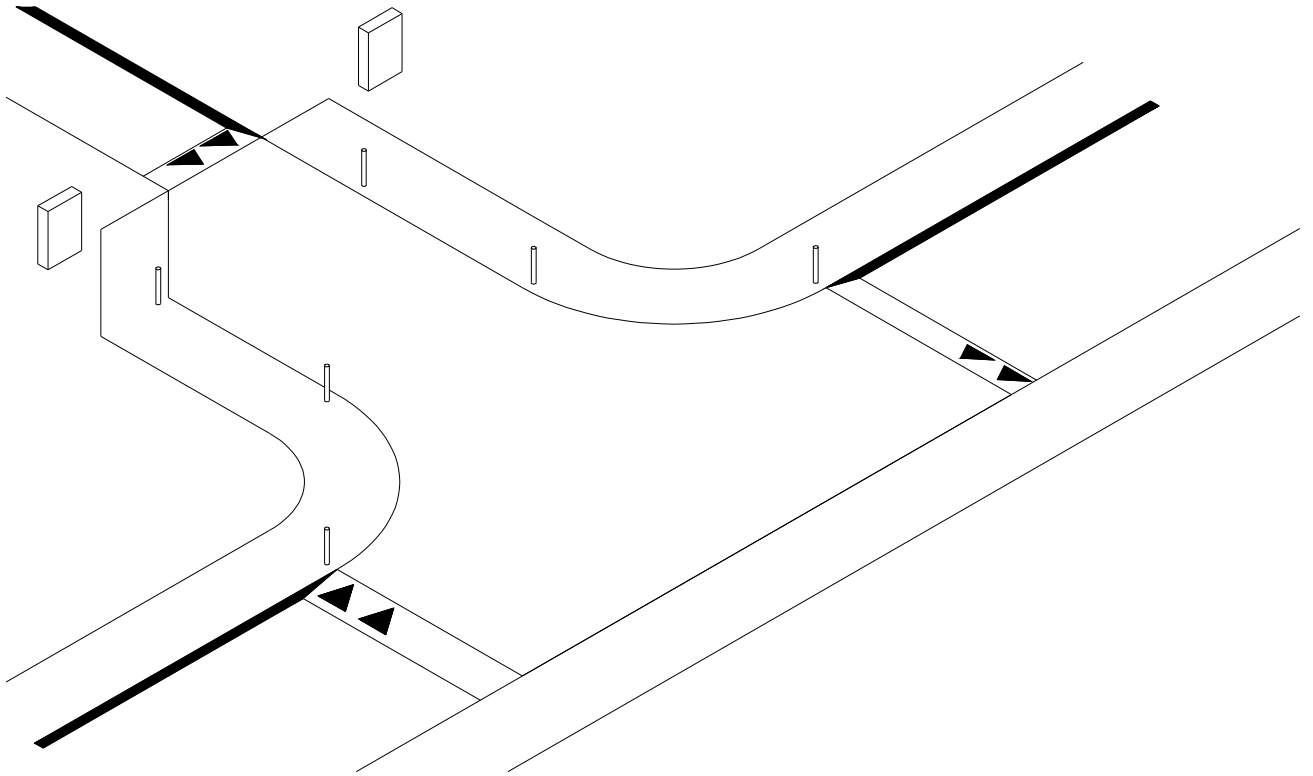
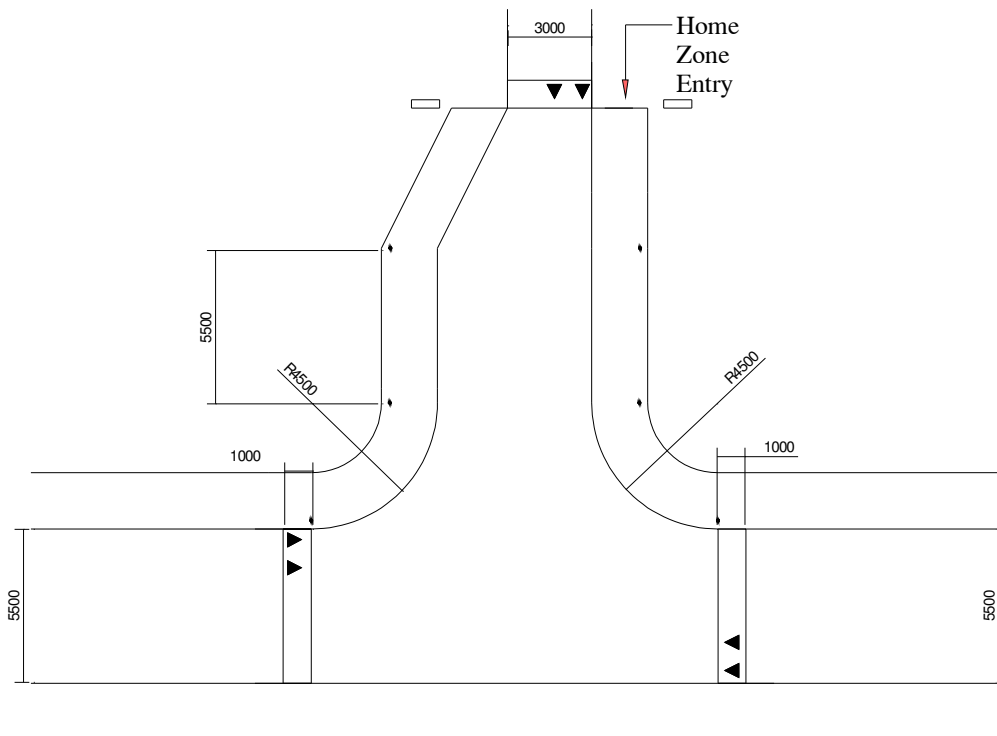

Figure 18.2 - Dropped Kerbs at Road Junctions



Isometric View



Plan View  
Scale 1:250

FIGURE 18.3 - TYPICAL HOME ZONE ENTRY DETAIL

### Distributor Road

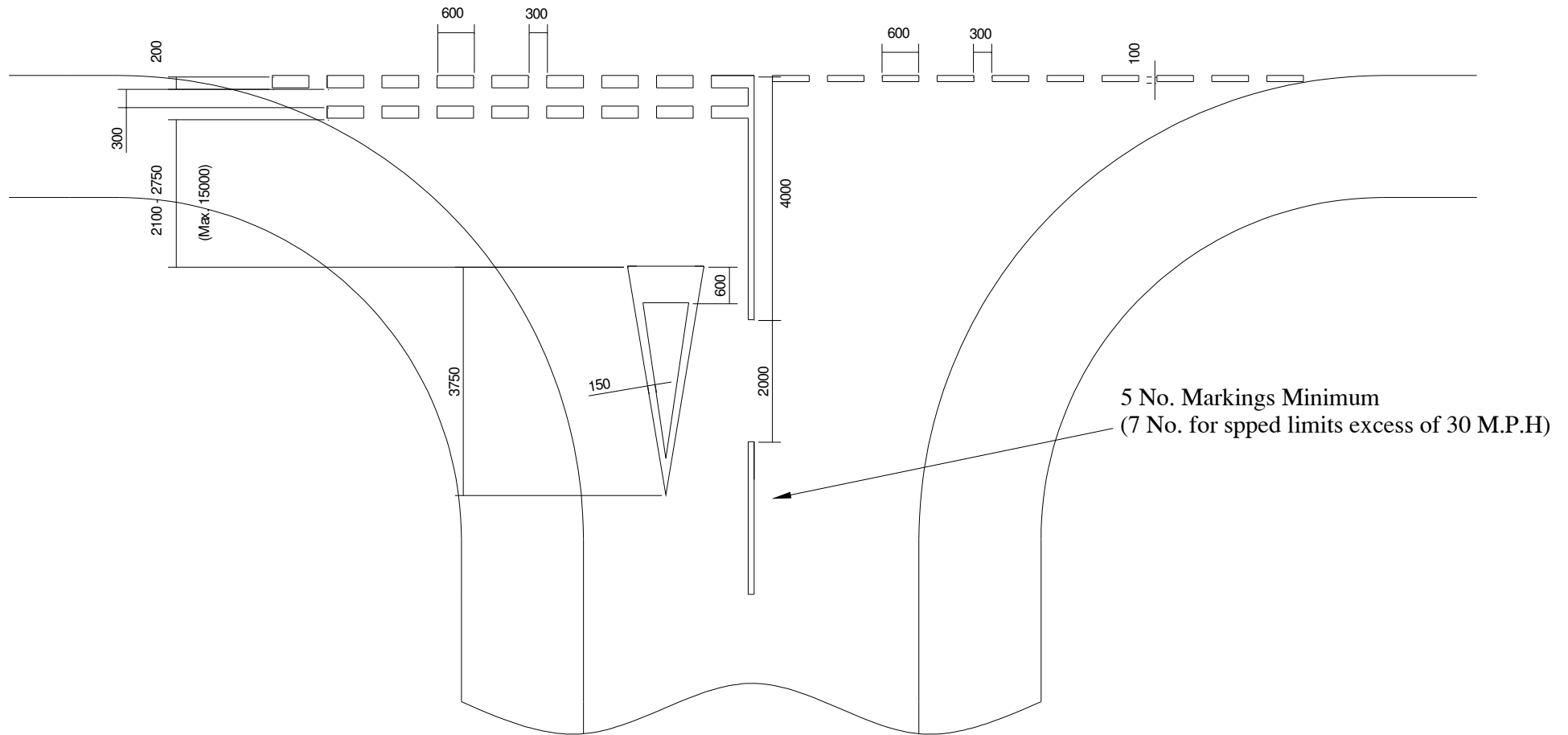

## FIGURE 18.4 - MARKINGS FOR USE WITH GIVE WAY SIGN

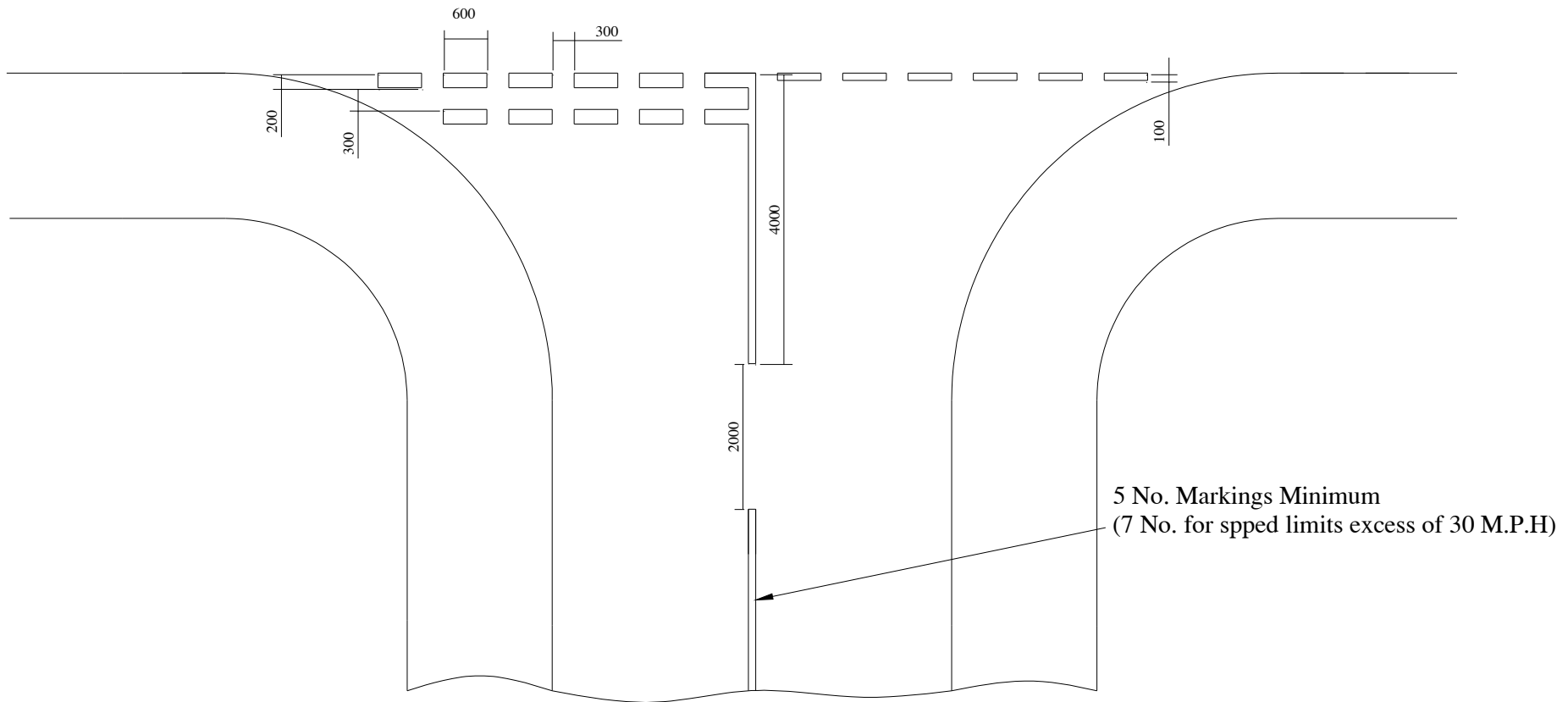

FIGURE 18.5 - MARKINGS FOR NO GIVE WAY SIGN

## 19. Turning Areas

### Turning Provision

19.1 It is desirable for road layouts to be designed so that service vehicles do not need to reverse on the public road. Wherever practicable this should be achieved by the provision of access roads in the form of loops off the LOCAL DISTRIBUTOR ROADS, thus avoiding the need for turning areas and minimising dead mileage for delivery and service vehicles.

### Turning Areas

19.2 In general, roads not of loop form (i.e. culs-de-sac) should preferably terminate in turning circles, which can be negotiated by all vehicles in forward gear. Where lack of space precludes the creation of a turning circle, or as a temporary solution as part of phased development, turning heads may be substituted, but the attendant dangers of reversing service vehicles should not be over looked. Any cul-de-sac over 110 metres long should have a turning circle.

### Geometry

19.3 The dimensions of turning areas should suit the characteristics of the largest vehicle making regular use of the facility. In Residential Roads these will normally be refuse collection vehicles, while in industrial/commercial development it may be necessary to cater for 15.5 metres long articulated vehicles or 18 metres long draw-bar trailers. The turning areas detailed in Figures 19.1, 19.2 and 19.3 are based on the turning circles between kerbs of these vehicles.

### Body Overhang

19.4 Where there is no adjacent footway, turning areas shall be provided with 2 metres wide verge or margin to allow for any overhang of vehicle bodies when manoeuvring.

### Parking

19.5 The layout of a development should be designed to discourage casual parking in turning areas. This may be achieved either by locating turning circles well clear of frontage development, or by arranging that premises and designated parking bays take access via the turning area.

### Informal Courtyards

19.6 In residential areas the use of less formal shapes for turning heads may be acceptable. Note that the shape should still incorporate the basic tuning head dimensions and be formed using standard radius kerbs.

Industrial Turning Circle  
Scale 1:500

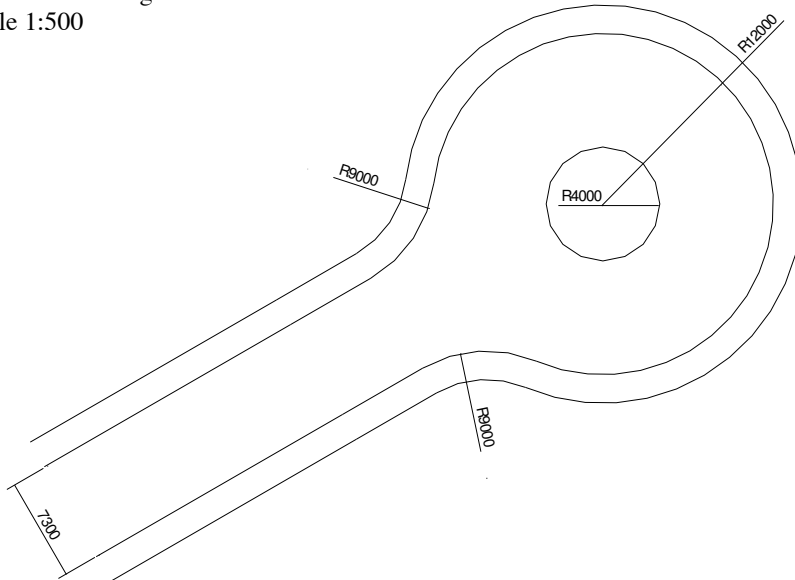

FIGURE 19.1(a)

Industrial Banjo  
Scale 1:500

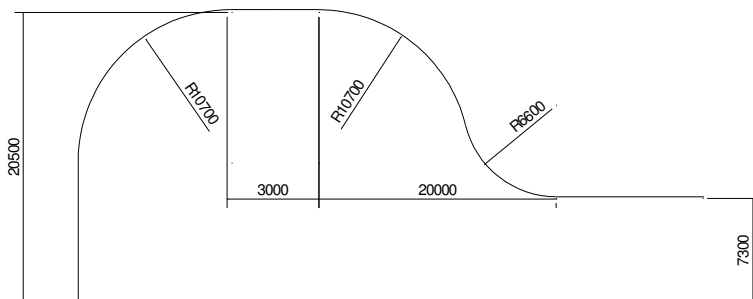

FIGURE 19.1(b)

# FIGURE 19.1 - INDUSTRIAL TURNING CIRCLE AND BANJO

Figure 19.2: Industrial and Residential Hammerhead **A**

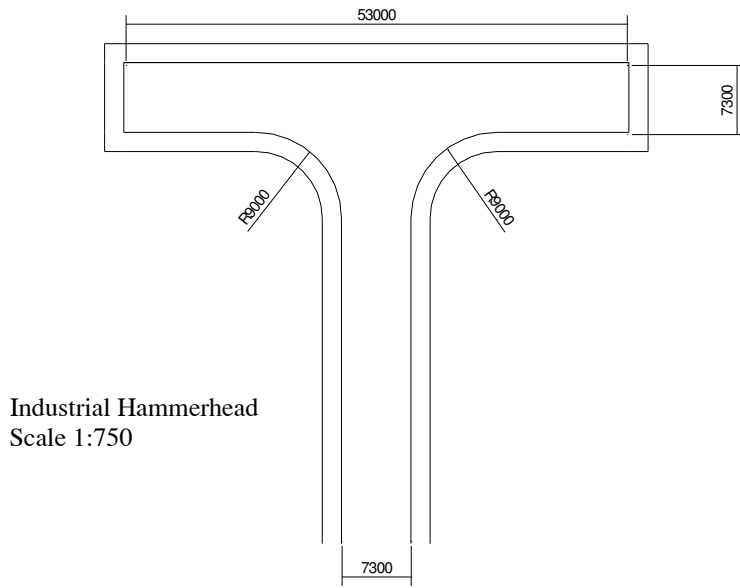

FIGURE 19.2(a)

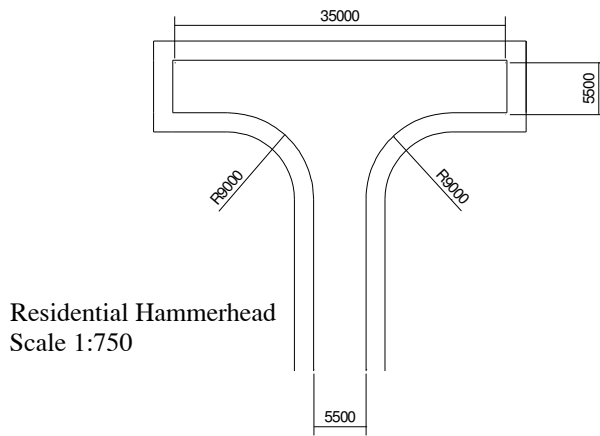

FIGURE 19.2(b)

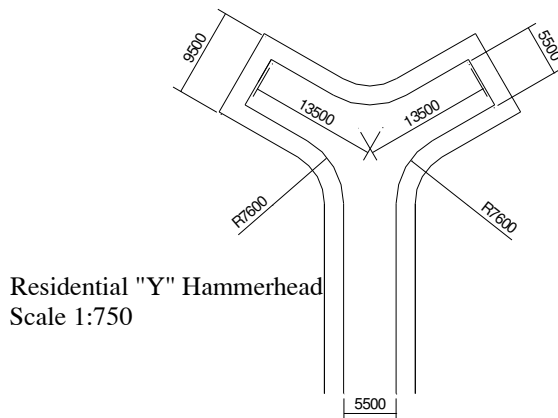

Figure 19.2(c)

# FIGURE 19.2 - INDUSTRIAL AND RESIDENTIAL HAMMERHEADS

Industrial Road Stub  
Scale 1:500

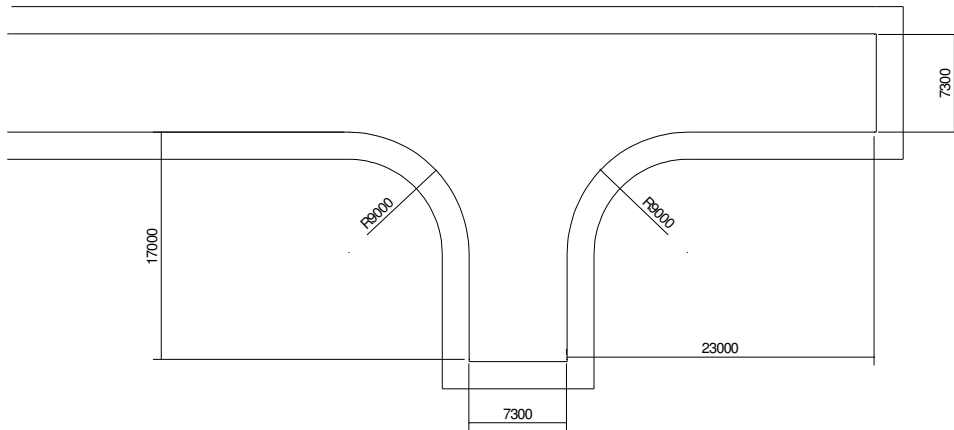

FIGURE 19.3(a)

Residential Road Stub  
Scale 1:500

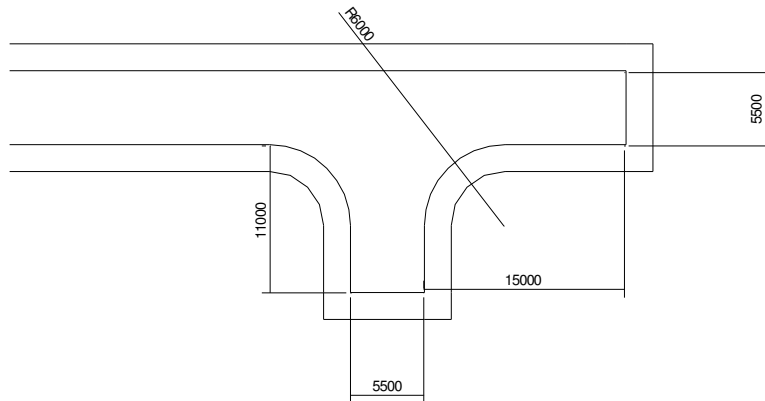

FIGURE 19.3(b)

## FIGURE 19.3 - INDUSTRIAL AND RESIDENTIAL ROAD STUBS

## 20. Traffic Calming

### General

20.1 All new residential roads within Aberdeenshire Council require to be constructed in such a manner as to be suitable for a 20mph mandatory speed limit zone. This speed limit must be self enforcing and the design of the overall residential road network must incorporate the necessary features to ensure speeds are kept within this limit. To comply with the statutory requirements for a 20mph speed limit zone traffic calming features must be provided at least every 100 metres.

In addition the layout of the residential road network should not encourage through traffic or inappropriate driver behaviour. Specific traffic calming measures also have a role to play in this aspect.

### Design Considerations



20.2 In assessing the design requirements for any scheme, various factors such as:

- (i) Design speed,
- (ii) Access for emergency vehicles,
- (iii) Pedestrian movements,
- (iv) Cyclists routes,
- (v) Public transport requirements,
- (vi) Parking provision,
- (vii) Street lighting,
- (viii) Environmental features/landscaping,
- (ix) Drainage requirements,
- (x) Accessibility,

will require to be given proper regard and accommodated or provision made for within the design.

All traffic calming proposals must comply with the relevant legislation and the Developer is responsible for ensuring compliance.

### Environmental Considerations



20.3 Lower vehicle speed will result in a reduction in the number and severity of accidents. The associated reduction in traffic noise due to the lower speeds will also be of benefit to residential areas. The relaxation of geometric standards and the reduction in road widths should allow the developer to incorporate areas for landscaping and amenity areas. A traffic calmed layout accompanied by environmental enhancements will help to create residential areas that protect vulnerable road users such as pedestrians and cyclists.

Application/  
Hierarchy 

20.4 Traffic calming measures are applicable to the road hierarchy as described below:

Road Hierarchy	Suitability for traffic calming
Primary and District Distributor Roads	In exceptional circumstances
Local Distributor Roads	Not normally required
Industrial Roads	Not normally used in industrial areas
Residential Roads	Compulsory

Application on  
Distributor  
Roads 

20.5 Where traffic calming is required on Distributor roads it should be used over an appropriate length and preceded at both ends by a gateway feature. The Local Roads Authority’s Representative will be able to give further guidance of the measures suitable for particular locations.

Application to  
Residential  
Roads 

20.6 As indicated previously all Residential Roads should be designed so as to restrict vehicles speeds by means of traffic calming measures to allow for the introduction of a 20mph zone or speed limit. It will be a condition of the Construction Consent that a traffic order is progressed by the Local Roads Authority. A charge of £675\* will be levied against the Developer for this service. (\* Details of the current charge for this service can be sought from the Local Roads Authority’s Representative).

A Gateway feature should be used to indicate the entrance to a 20mph zone. Preferably this will be used at the junction giving access to the area, but can be used at other locations, at the discretion of the Local Roads Authority’s Representative.

Types of Traffic  
Calming 

20.7 Traffic calming features can be divided into 6 main types, namely:

- Vertical Measures
- Lateral Measures
- Measures which affect the carriageway width
- Geometric alignment
- Measures at junctions
- Gateways

Features from these main types are outlined below. It is important to consider the overall effect of the features proposed on the entire development. Combinations should be chosen which reduce and restrict the vehicle speeds while protecting vulnerable road users, such as cyclists and pedestrians.

Speed  
Cushion 

- 20.8 Speed cushions are suitable for use on any width of road and are particularly suitable for routes that have high HGV figures or are bus routes.

The maximum vertical displacement of the speed cushion should be 75mm. Each speed cushion is formed from two taper sections and a raised plateau, as shown in Figure 20.4. The speed cushions should be placed across the carriageway width in such a manner as to impede the running line for cars while permitting buses and emergency vehicles to pass over them. Figure 20.4 shows a typical spacing that will allow this to occur.

The speed cushions must be designed, signed, and illuminated in accordance with the Road Hump (Scotland) Regulations 1998 and The Road Humps and Traffic Calming (Scotland) Amendment Regulations 1999. Reference should also be made to the SEDD Circular 6/2001- 20mph Speed Limits.

Road Hump 

- 20.9 Road humps are suitable for any width of carriageway. They should ideally be constructed over the entire width of the carriageway, to aid pedestrian movements.

The maximum vertical displacement of the road hump should be 75mm. The road hump is formed from a circular arc, as shown in Figure 20.1. The erection of vertical features such as bollards can help to enhance the effectiveness of the road hump.

The road humps must be designed, signed, and illuminated in accordance with the Road Hump (Scotland) Regulations 1998 and The Road Humps and Traffic Calming (Scotland) Amendment Regulations 1999. Reference should also be made to the SEDD Circular 6/2001- 20mph Speed Limits.

The use of road humps should be restricted on bus routes. Typical Construction is shown in Figure 20.5.

Speed Table 

- 20.10 Speed tables are suitable for any width of carriageway. They should ideally be constructed over the entire width of the carriageway, to aid pedestrian movements.

The maximum vertical displacement of the speed table should be 75mm. The speed table is formed from two taper sections and a raised plateau, as shown in Figure 20.2. An alternative edge detail is shown in Figure 20.3. This allows the channel line to remain uninterrupted and may aid drainage in certain circumstances. This layout would be acceptable if predicted pedestrian movements are low.

The speed tables must be designed, signed, and illuminated in accordance with the Road Hump (Scotland) Regulations 1998 and The Road Humps and Traffic Calming (Scotland) Amendment Regulations 1999. Reference should also be made to the SEDD Circular 6/2001- 20mph Speed Limits.

The use of speed tables should be restricted on bus routes. Typical Construction is shown in Figure 20.5.

Raised Junction 

- 20.11 Raised junctions are suitable for any road width. They must be constructed over the entire junction area; ideally the raised plateau should be extended to at least the tangent points of the junction radii.

The maximum vertical deflection should be 75mm. The raised junction is formed by taper sections on each approach to the junction and a raised plateau covering the entire area, as shown in Figure 20.6. Bollards may be required around the junction radii to prevent vehicle overrun due to the effective removal of the kerb upstand.

The raised junction must be designed, signed, and illuminated in accordance with the Road Hump (Scotland) Regulations 1998 and The Road Humps and Traffic Calming (Scotland) Amendment Regulations 1999. Reference should also be made to the SEDD Circular 6/2001- 20mph Speed Limits.

## Lateral Measures

### Chicanes

- 20.12 Chicanes are not suitable for use on all widths of road. If the road is expected to carry a high volume of commercial vehicles or if it is a bus route consideration should be given to the use of overrun areas.

Chicanes can take many various forms and several types have been outlined below.

Irrespective of the type of chicane adequate provision should be made in the design for cyclists and a separate cycletrack or facility for cyclists to bypass the feature should be included.

The location and spacing of chicanes will be dependent on the road layout and features but, in general, spacing between chicanes should lie within the range of 40-60 metres.

Some typical layouts for chicanes are shown in Figures 20.7, 20.8 and 20.9. It should be noted that facilities for cyclists have not be included in these layouts.

The chicanes must be designed, signed, and illuminated in accordance with the Roads (Traffic Calming) (Scotland) Regulations 1994 and The Road Humps and Traffic Calming (Scotland) Amendment Regulations 1999. Reference should also be made to the SEDD Circular 6/2001- 20mph Speed Limits.

### Measures which affect carriageway width

### Pinch Points

- 20.13 These are suitable for all widths of road. It is most suited to low volume roads where the opposing flows are balanced. A typical detail for a pinch point is shown in Figure 20.10.

If this feature is to be used on a bus route or a route where a large number of heavy vehicles are expected then consideration should be given to the incorporation of overrun areas.

Careful consideration must be given to the safe passage of pedestrians and of cyclists. Separate cycletracks or by pass channels for cyclists should be incorporated into this form of traffic calming feature to ensure that they are afforded adequate protection from vehicles.

The pinch point must be designed, signed, and illuminated in accordance with the Roads (Traffic Calming) (Scotland) Regulations 1994 and The Road Humps and Traffic Calming (Scotland) Amendment Regulations 1999. Reference should also be made to the SEDD Circular 6/2001- 20mph Speed Limits.

Pedestrian  
Refuges/ Traffic  
Islands 

- 20.14 Traffic islands are suitable for use on all categories of roads and should be provided as an aid to pedestrian movements at locations where a significant pedestrian movement is anticipated or where difficulty in crossing may be experienced due to the volume of traffic.

A minimum central island width of 1.5m should be provided with carriageway widths of 3.0m, with overrun areas extending the carriageway width to 3.5m. A typical layout is shown on Figure 20.11. It should be noted that facilities for cyclists have not been included in this layout. Consideration should be given to the provision of separate cycletracks or a facility for cyclists to bypass the feature.

Carriageway  
Narrowings 

- 20.15 Carriageway narrowings are suitable for all widths of road. This type of feature is best suited to roads that have relatively balanced vehicular flows. The correct siting of these features can also provide significant benefits to pedestrians by reducing the width of carriageway that they must negotiate.

Careful consideration must be given to the safe passage of cyclists. Separate cycletracks or by pass channels for cyclists should be incorporated into this form of traffic calming feature to ensure that they are afforded adequate protection from vehicles. A typical carriageway narrowing is shown in Figure 20.12

The carriageway narrowing must be designed, signed, and illuminated in accordance with the Roads (Traffic Calming) (Scotland) Regulations 1994 and The Road Humps and Traffic Calming (Scotland) Amendment Regulations 1999. Reference should also be made to the SEDD Circular 6/2001-20mph Speed Limits.

Geometric Alignment

Speed Bend 

- 20.16 Speed bends are suitable for bends between 80 and 100 degrees.

Speed bends must be accompanied by good visibility across the bend. In addition a 15 metre straight is required between a speed bend and adjacent reverse curve.

A typical layout for a speed bend is shown in Figure 20.13

The speed bend must be designed, signed, and illuminated in accordance with the Roads (Traffic Calming) (Scotland) Regulations 1994 and The Road Humps and Traffic Calming (Scotland) Amendment Regulations 1999. Reference should also be made to the SEDD Circular 6/2001- 20mph Speed Limits.

Lateral Shift in Alignment 

20.17 A Lateral Shift in Alignment is suitable for any road width.

The design of the alignment should take full consideration of the type of vehicles that are likely to use the road. Overrun areas can be incorporated into the lateral shift to ensure that buses and commercial vehicles can negotiate the feature.

A typical layout for a lateral shift in alignment is shown in Figure 20.14.

The Lateral Shift in Alignment must be designed, signed, and illuminated in accordance with the Roads (Traffic Calming) (Scotland) Regulations 1994 and The Road Humps and Traffic Calming (Scotland) Amendment Regulations 1999. Reference should also be made to the SEDD Circular 6/2001-20mph Speed Limits.

Measures at Junctions

Overrun Corners 

20.18 Overrun Corners can be used at any junction

The design of the overrun feature should comply with Section 20.16. This type of feature will reduce vehicle speed entering the junction and may be suitable for the start of a 20mph zone. The overrun area allows larger vehicles and buses to safely negotiate the junction.

A typical layout for an overrun corner is shown in Figure 20.15.

The Overrun Corners must be designed, signed, and illuminated in accordance with the Roads (Traffic Calming) (Scotland) Regulations 1994 and The Road Humps and Traffic Calming (Scotland) Amendment Regulations 1999. Reference should also be made to the SEDD Circular 6/2001-20mph Speed Limits.

Gateways

Gateway on a Straight 

20.19 A gateway feature must indicate the start of a 20mph zone.

When used on a straight the gateway should also incorporate a physical speed reducing feature, as outlined above.

The use of vertical elements such as planting and signing may be useful to increase the prominence of the gateway.

20.20 The use of a gateway at the junction of a side road will be the most common usage. Most 20mph Zones will start at a junction and vehicle speeds will be low due to negotiating the junction. Tight radii on the junction and overrun areas may be used to ensure that vehicle speeds are reduced to an appropriate level.

The gateway should incorporate vertical features that allow signs etc to be prominently displayed. The use of vertical features will also increase the awareness of the driver.

A traffic calming feature will be required soon after the gateway to ensure that traffic speeds do not increase.

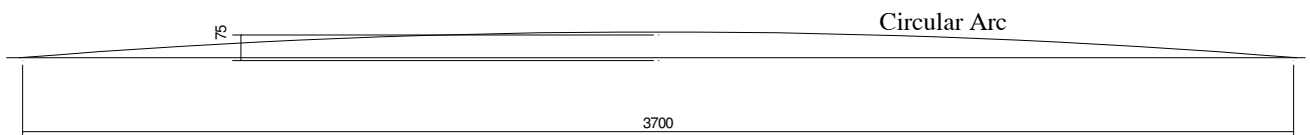
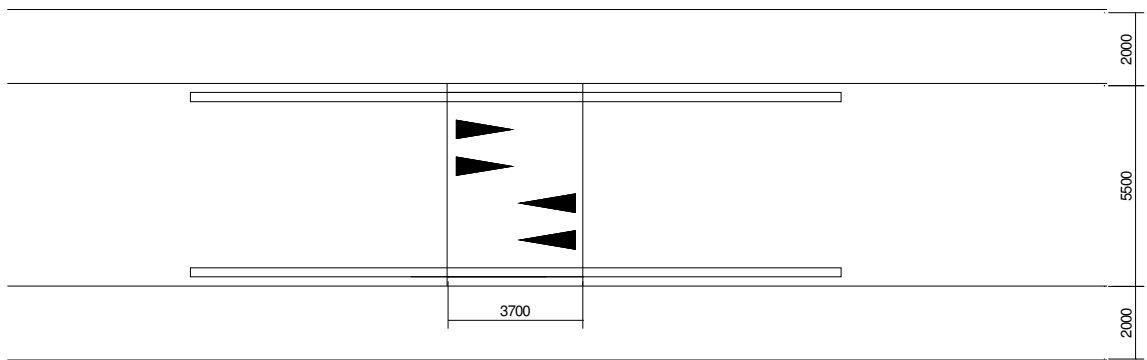
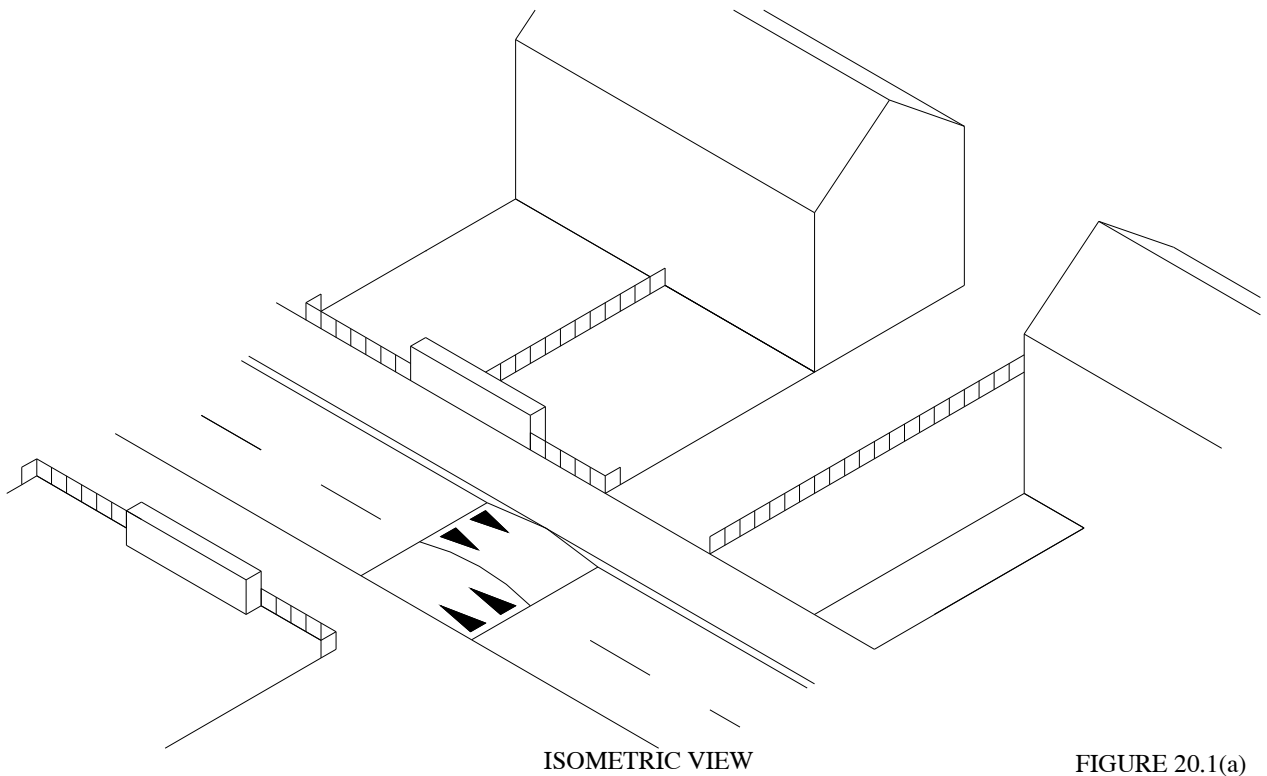

# FIGURE 20.1 - ROUND TOPPED ROAD HUMPS

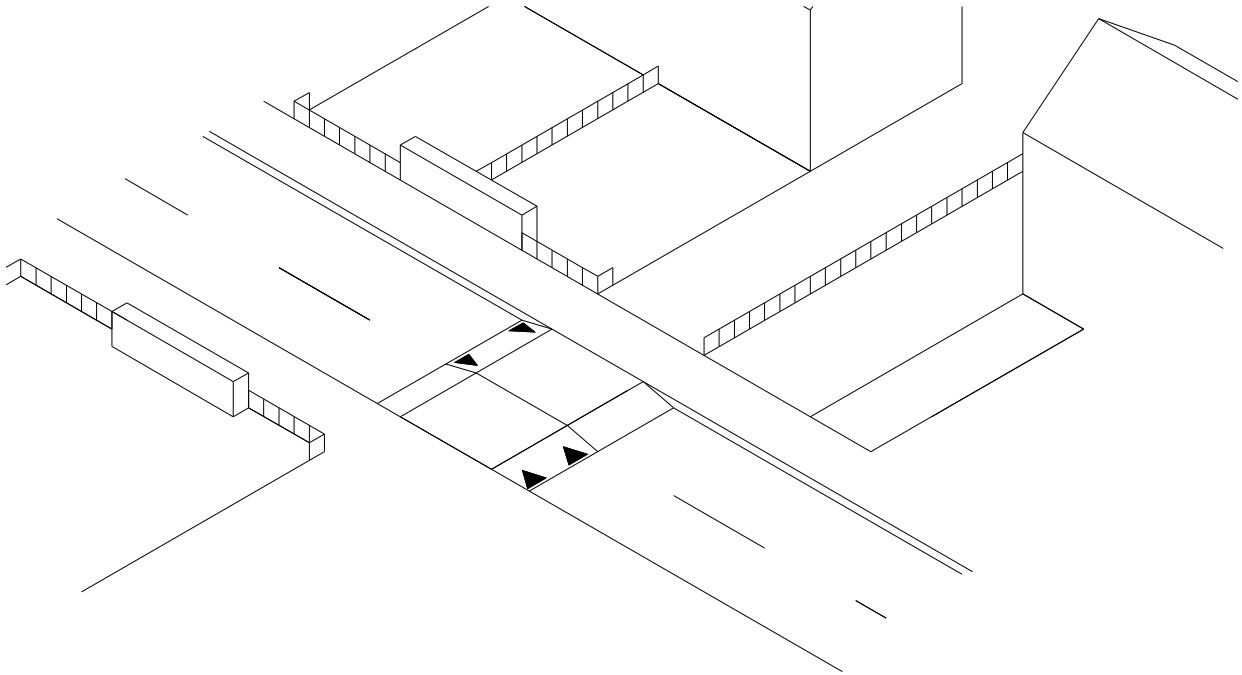

ISOMETRIC VIEW

FIGURE 20.2(a)

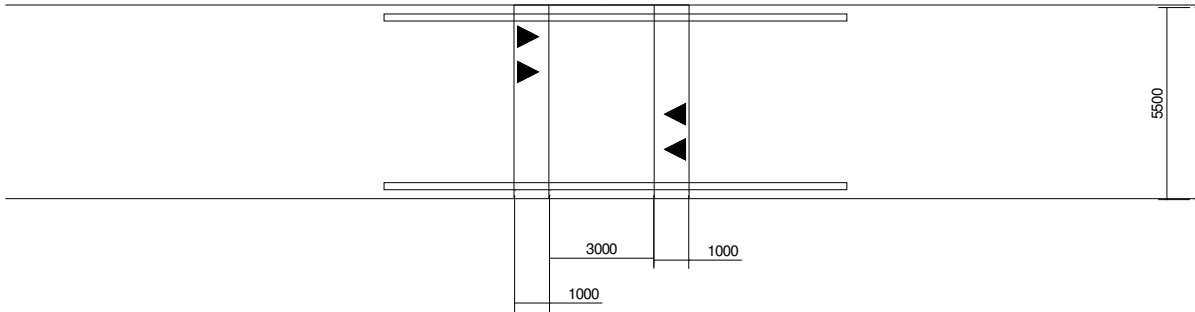

PLAN VIEW  
SCALE 1:200

FIGURE 20.2(b)

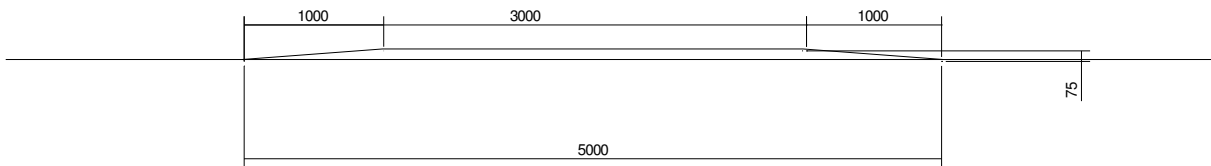

ELEVATION VIEW

FIGURE 20.2(b)

# FIGURE 20.2 - SPEED TABLE

Figure 20.3: Tapered Edge Speed Table and Road Hump 

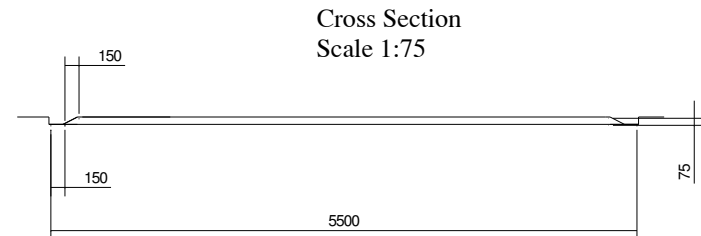
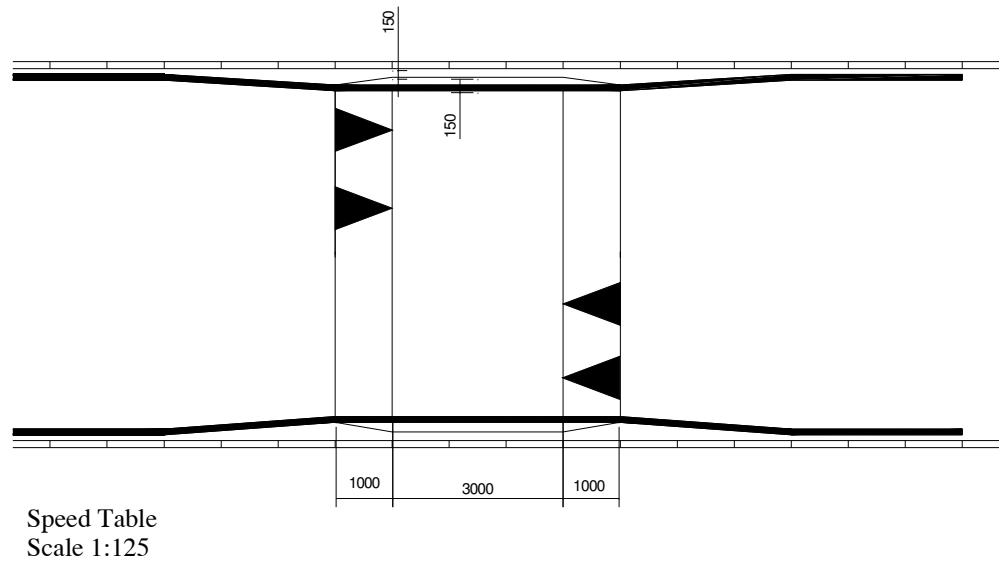
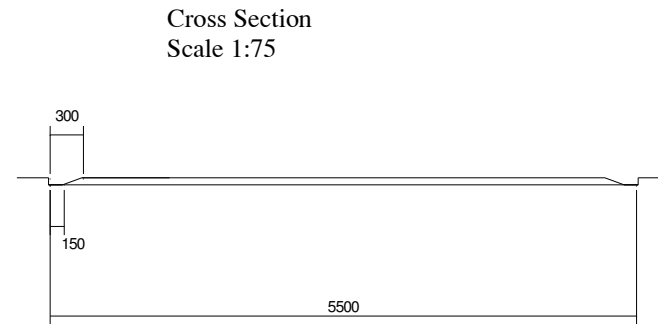
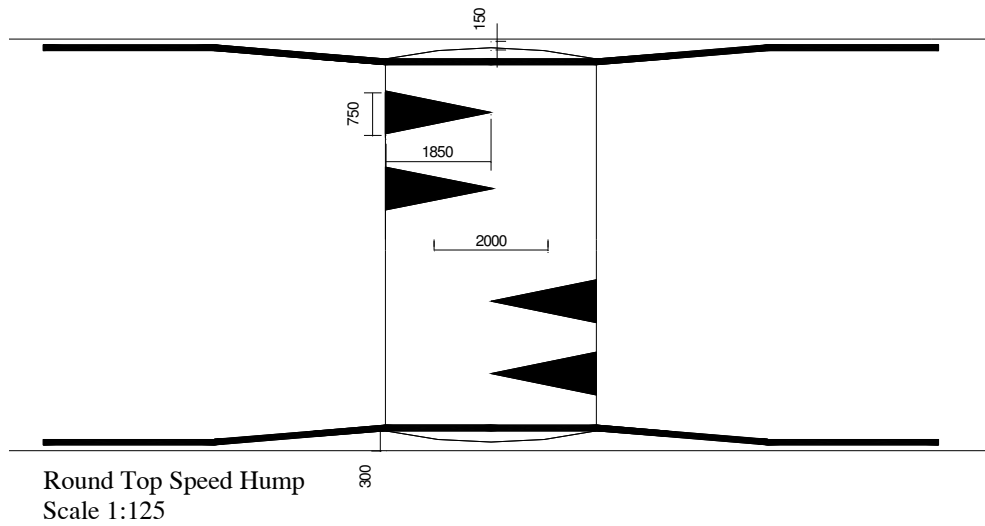
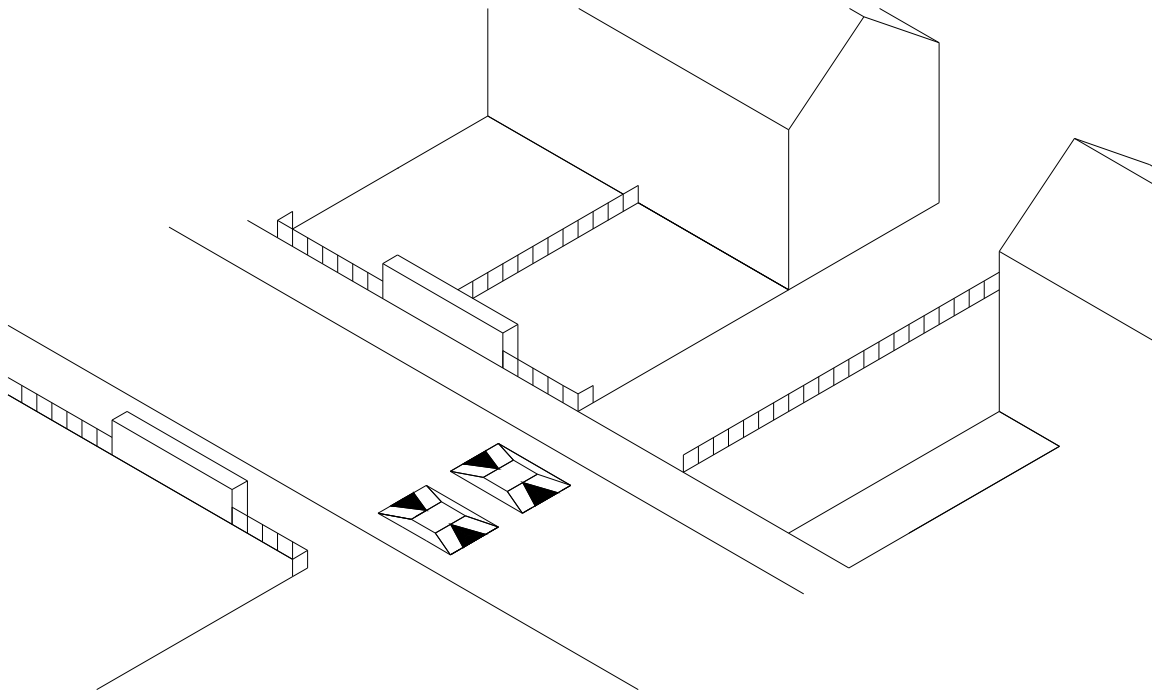
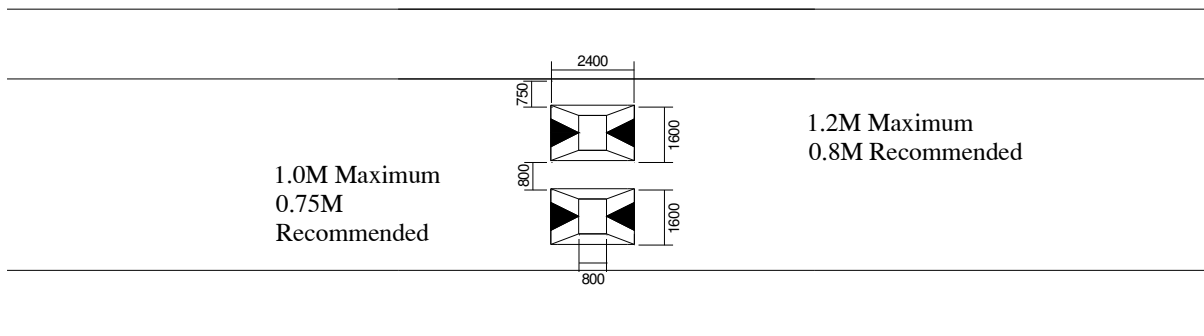

Figure 20.3 - Tapered Edge Speed Table and Road Hump



ISOMETRIC VIEW

FIGURE 20.4(a)



PLAN VIEW  
SCALE 1:200

FIGURE 20.4(b)

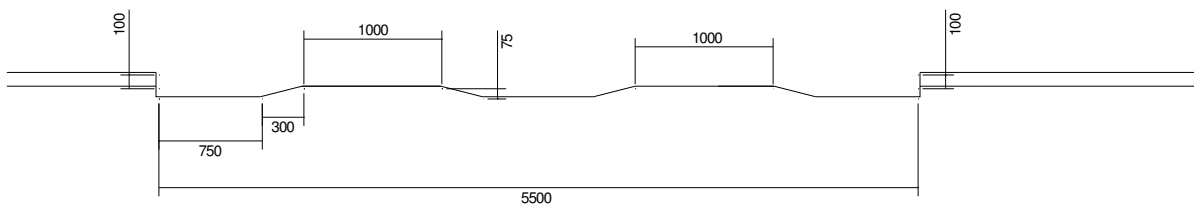

CROSS SECTION  
SCALE 1:50

FIGURE 20.4(b)

## FIGURE 20.4 - SPEED CUSHION

Figure 20.5: Road Hump Typical Construction Details 

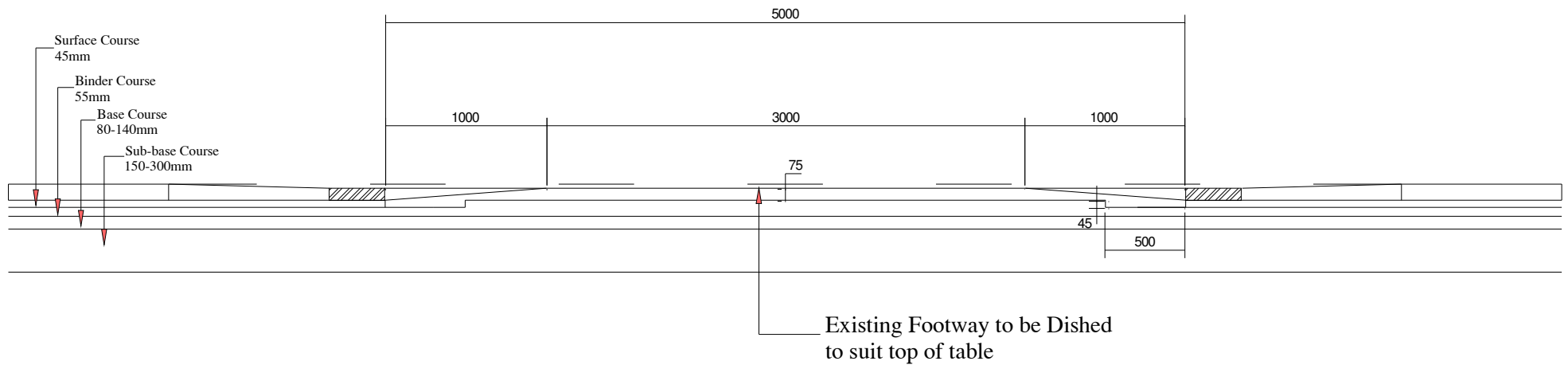

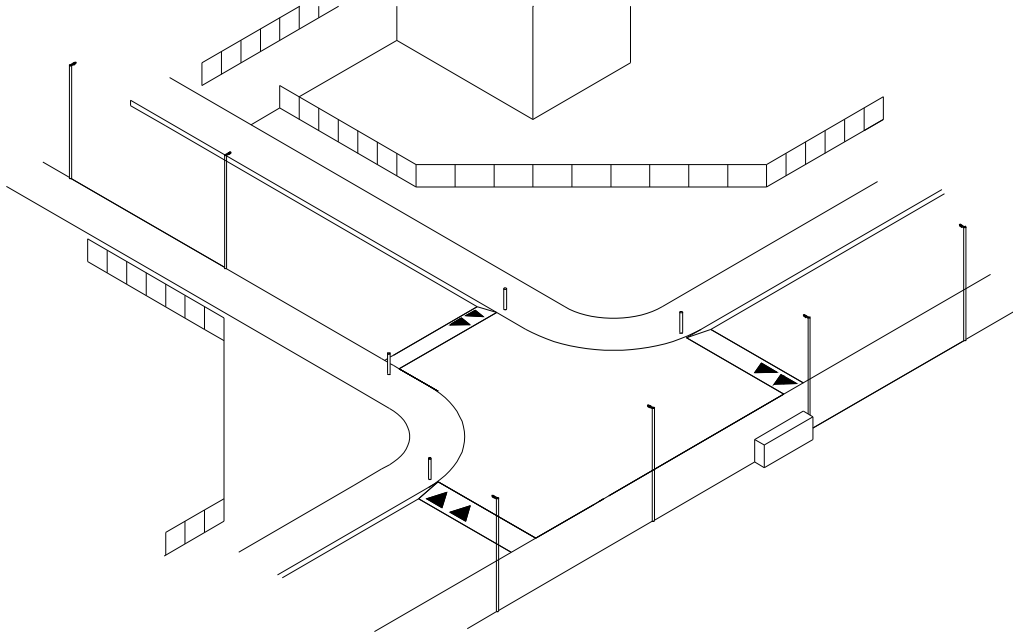

Figure 20.5 - Road Hump Typical Construction Details

Figure 20.6: Raised Junction 



ISOMETRIC VIEW

FIGURE 20.6(a)

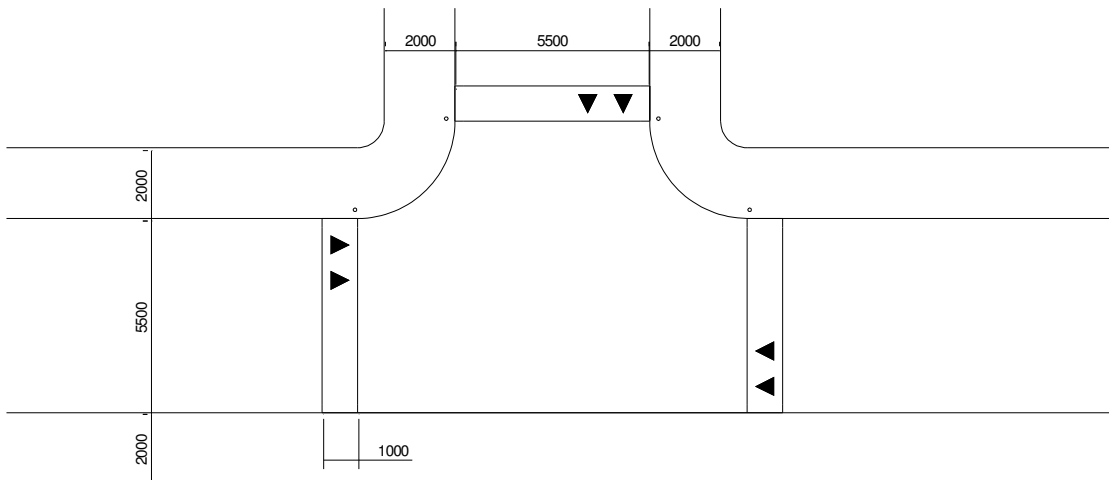

PLAN VIEW  
SCALE 1:200

FIGURE 20.6(b)

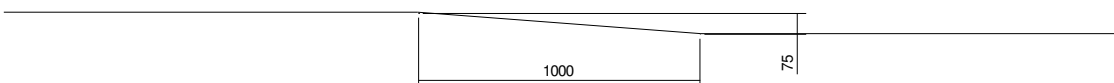

Part Section Through Raised Junction  
SCALE 1:25

FIGURE 20.6(b)

# FIGURE 20.6 - RAISED JUNCTION

Figure 20.7: Chicane Type 1 

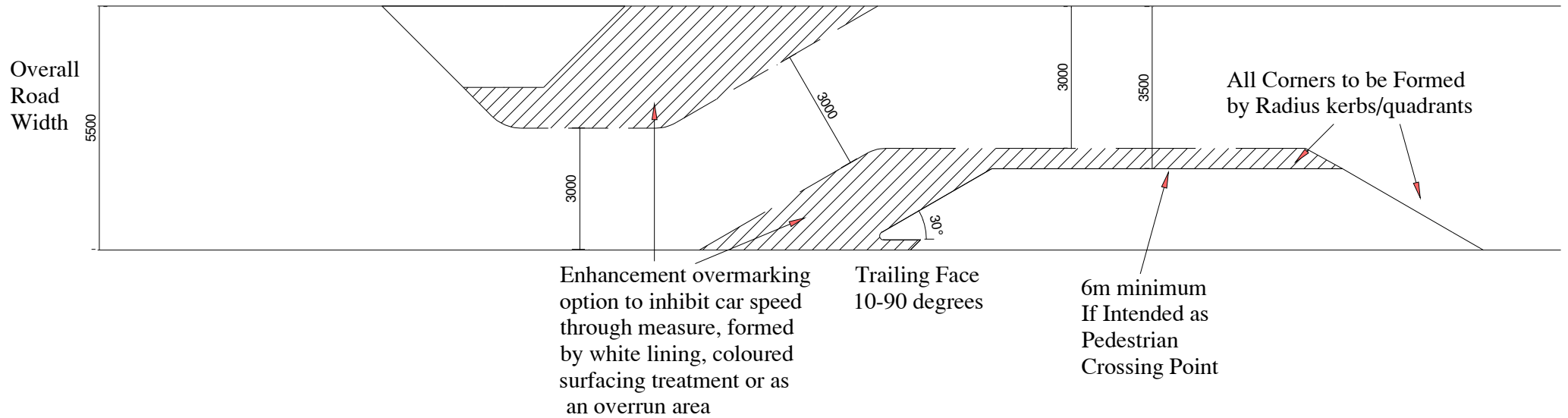

Figure 20.7

## FIGURE 20.7 - CHICANE TYPE 1

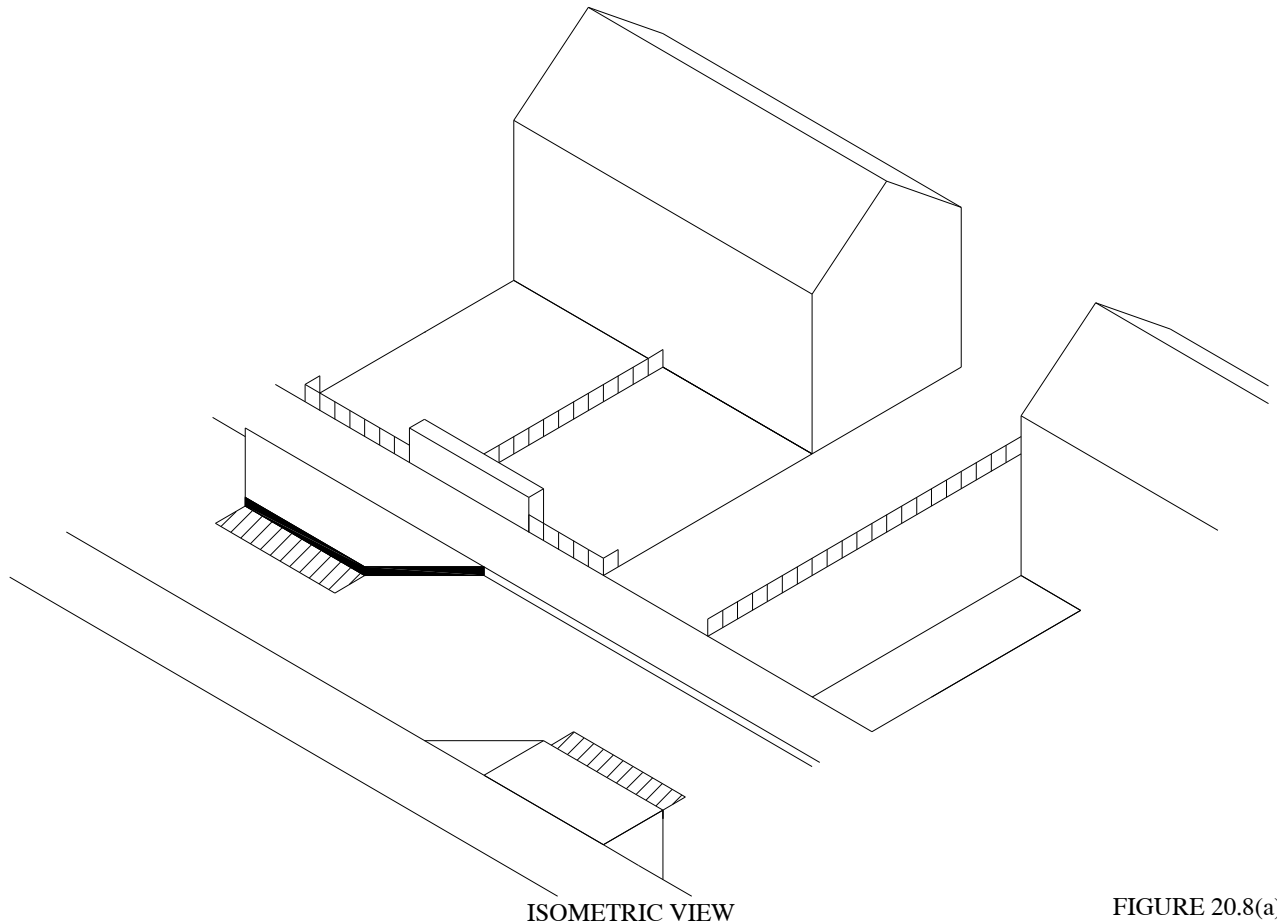

FIGURE 20.8(a)

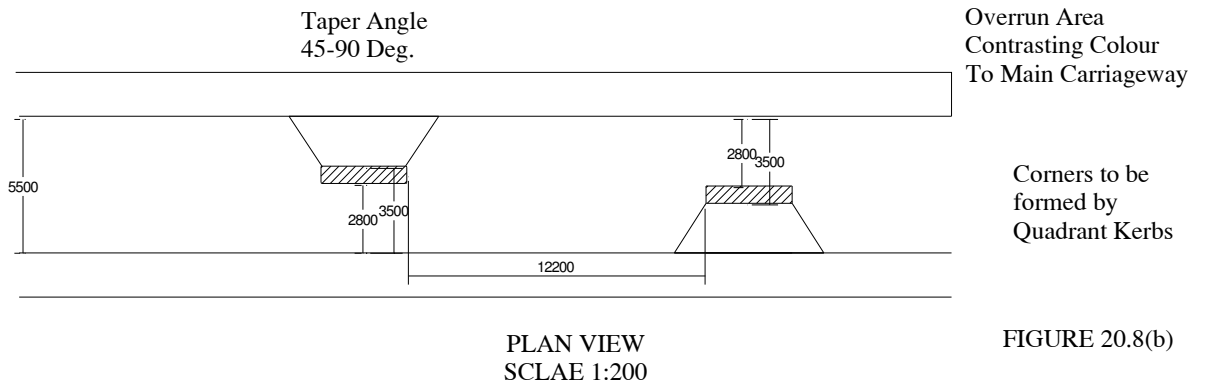

FIGURE 20.8(b)

## FIGURE 20.8 - CHICANE TYPE 2

Figure 20.9: Chicane Type 3 

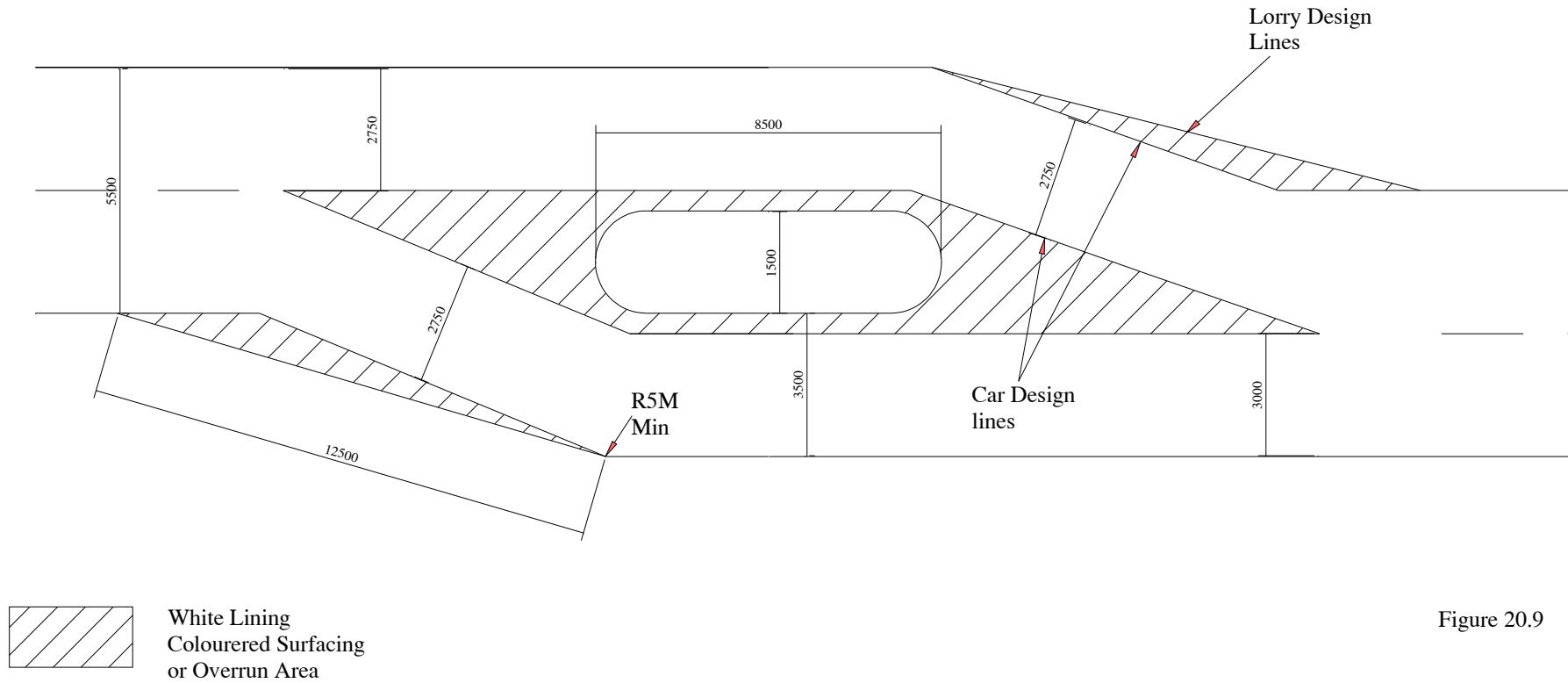



Figure 20.9

# FIGURE 20.9 - CHICANE TYPE 3

Figure 20.10: Pinch Point 

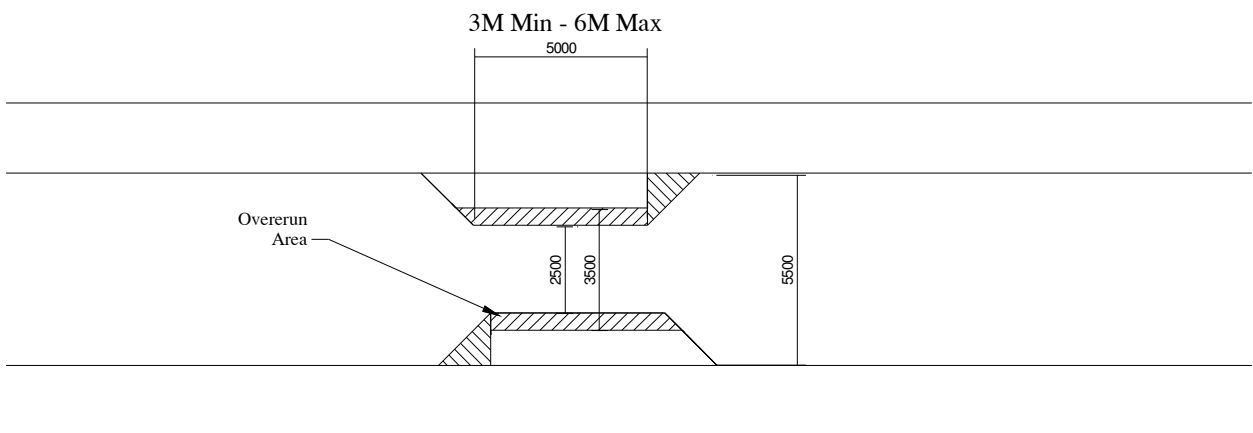
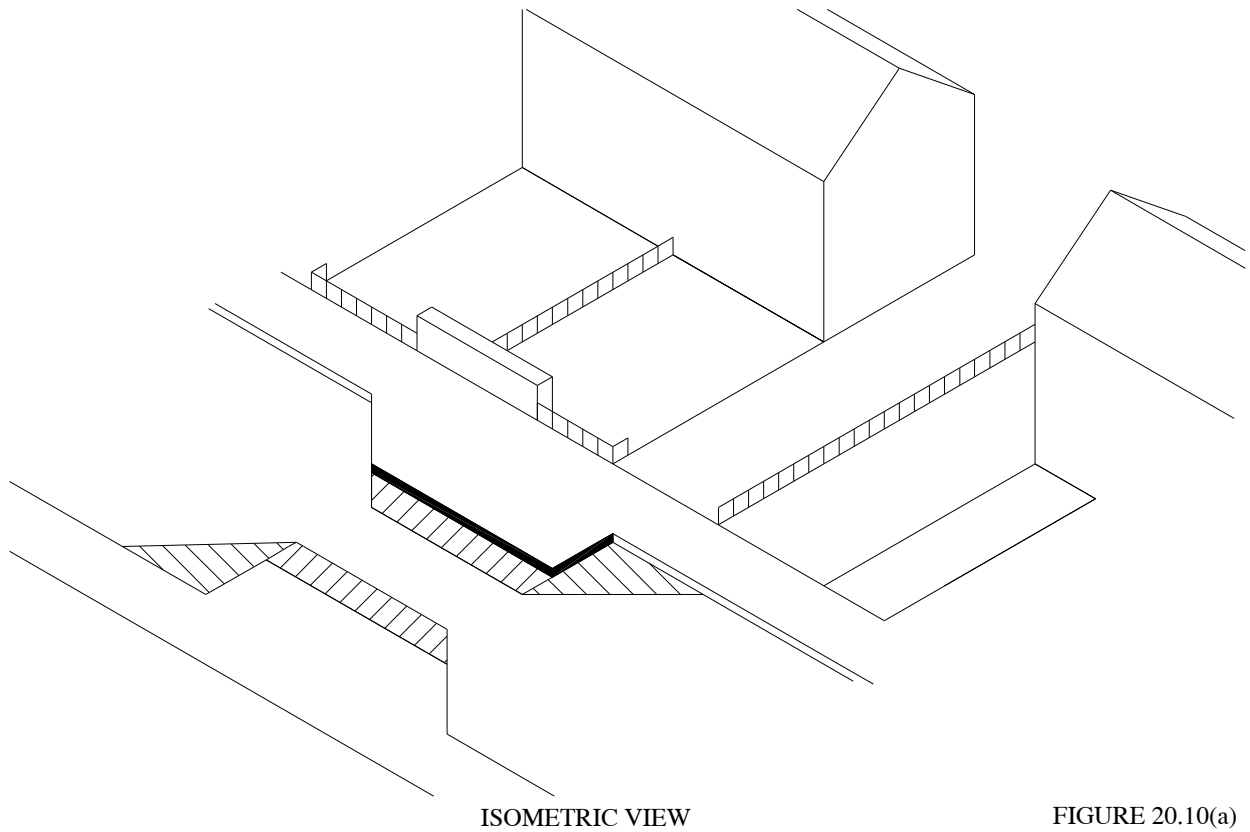
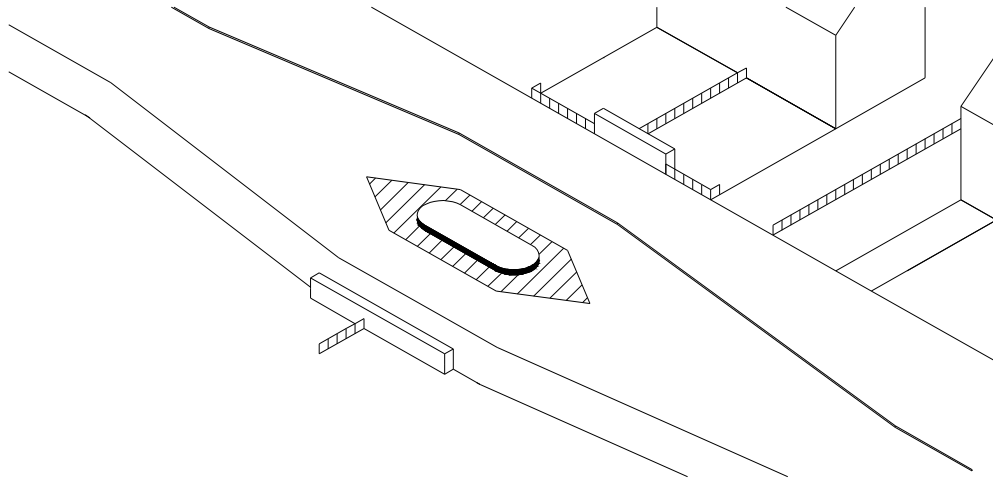
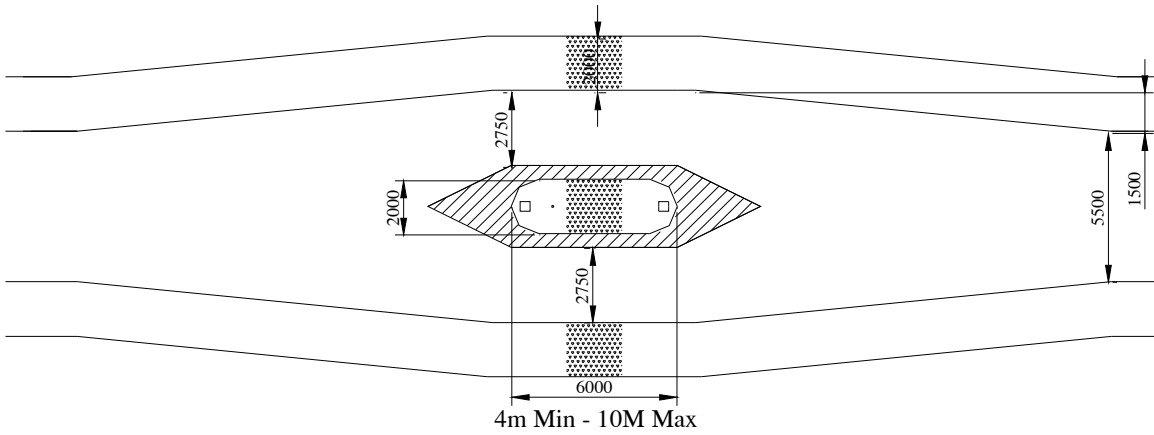

FIGURE 20.10 - PINCH POINT



ISOMETRIC VIEW

FIGURE 20.11(a)



PLAN VIEW  
SCALE 1:200

FIGURE 20.11(b+c)

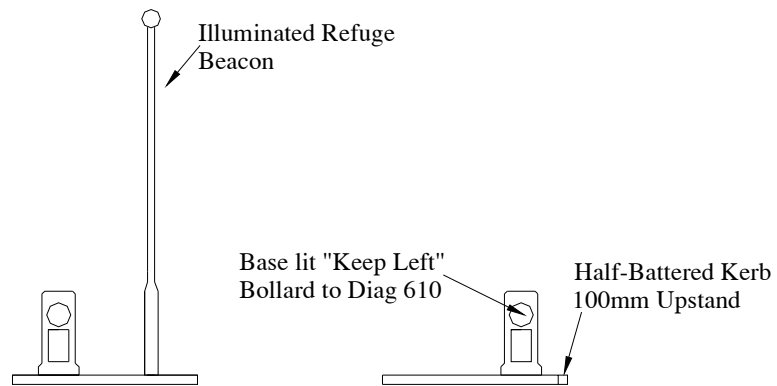

ELEVATION VIEW  
SCALE 1:75

FIGURE 20.11(d)

# FIGURE 20.11 - CENTRAL ISLAND

Figure 20.12: Width Reduction in Carriageway 

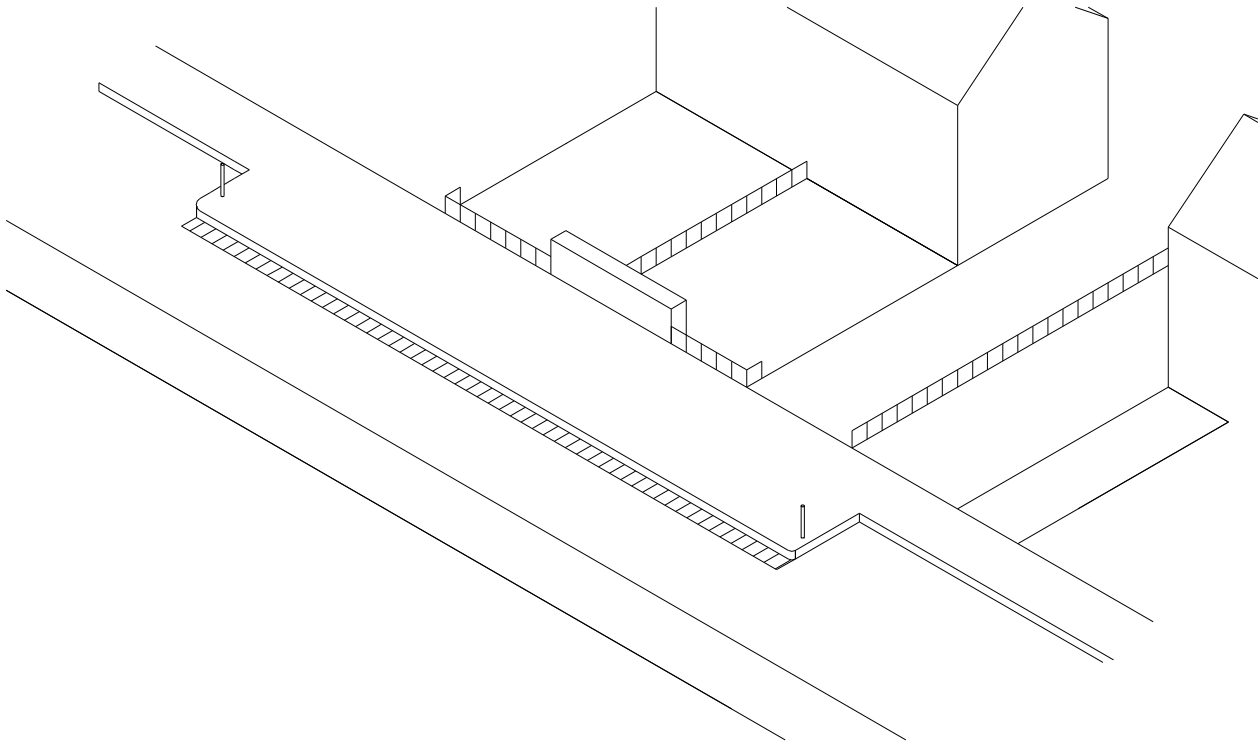

ISOMETRIC VEIW

FIGURE 20.12(a)

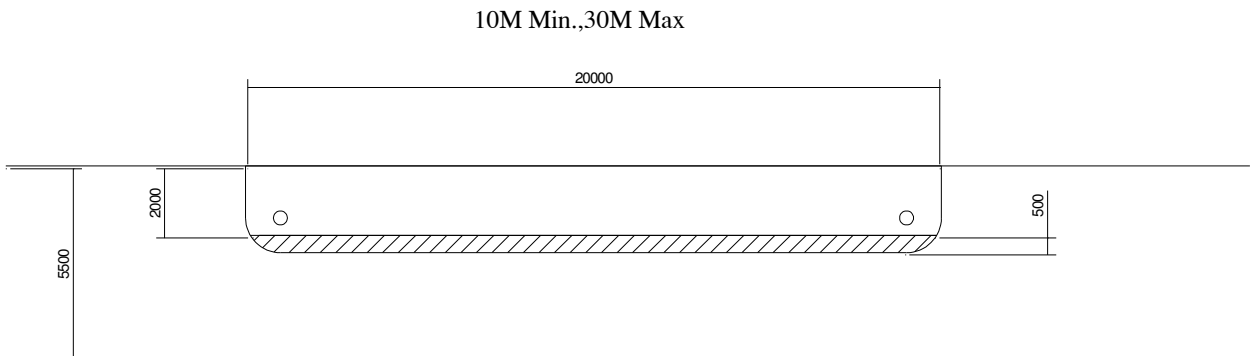

PLAN VIEW  
SCALE 1:200

FIGURE 20.12(b)

## FIGURE 20.12 - WIDTH REDUCTION IN CARRIAGEWAY

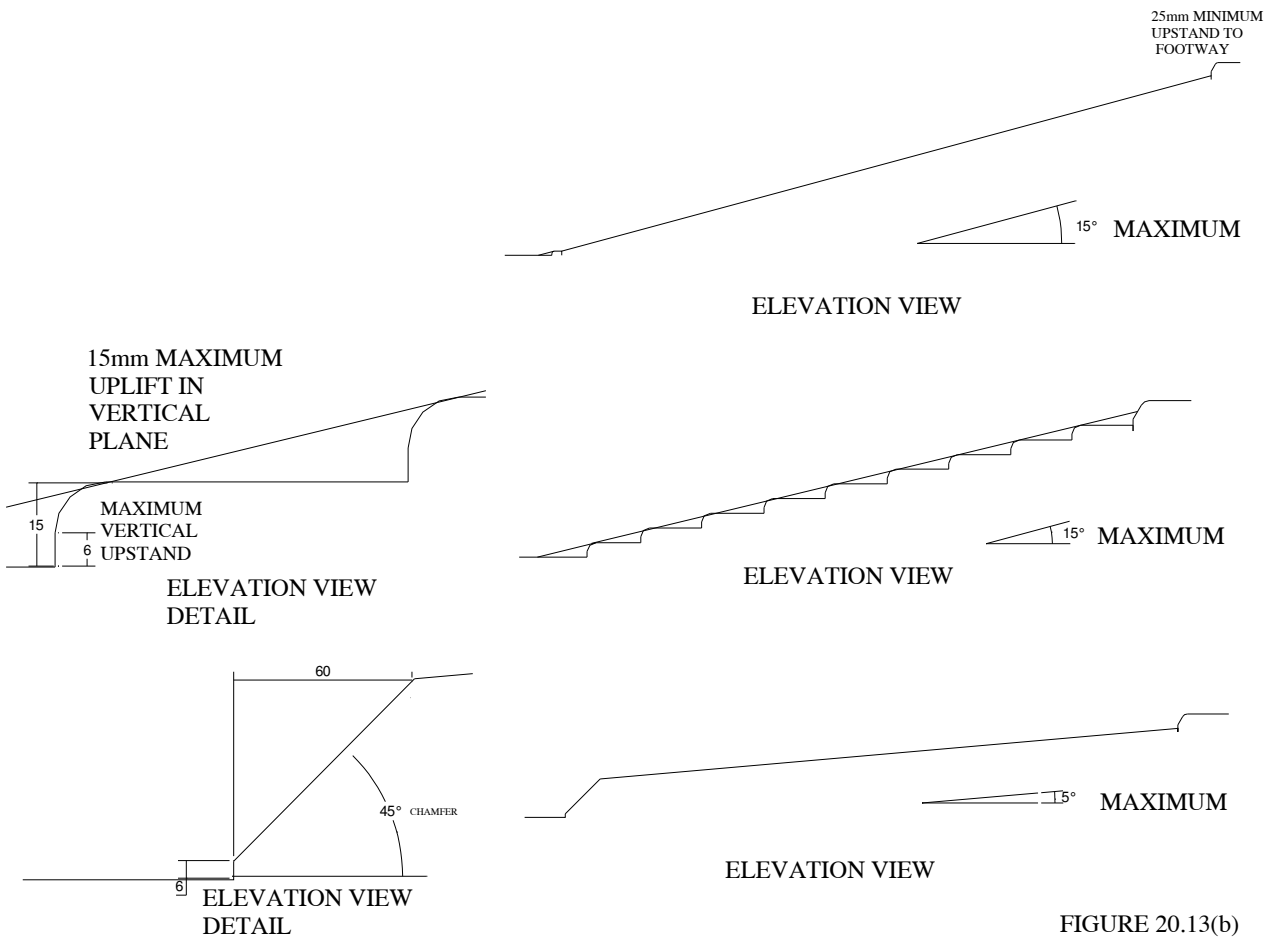
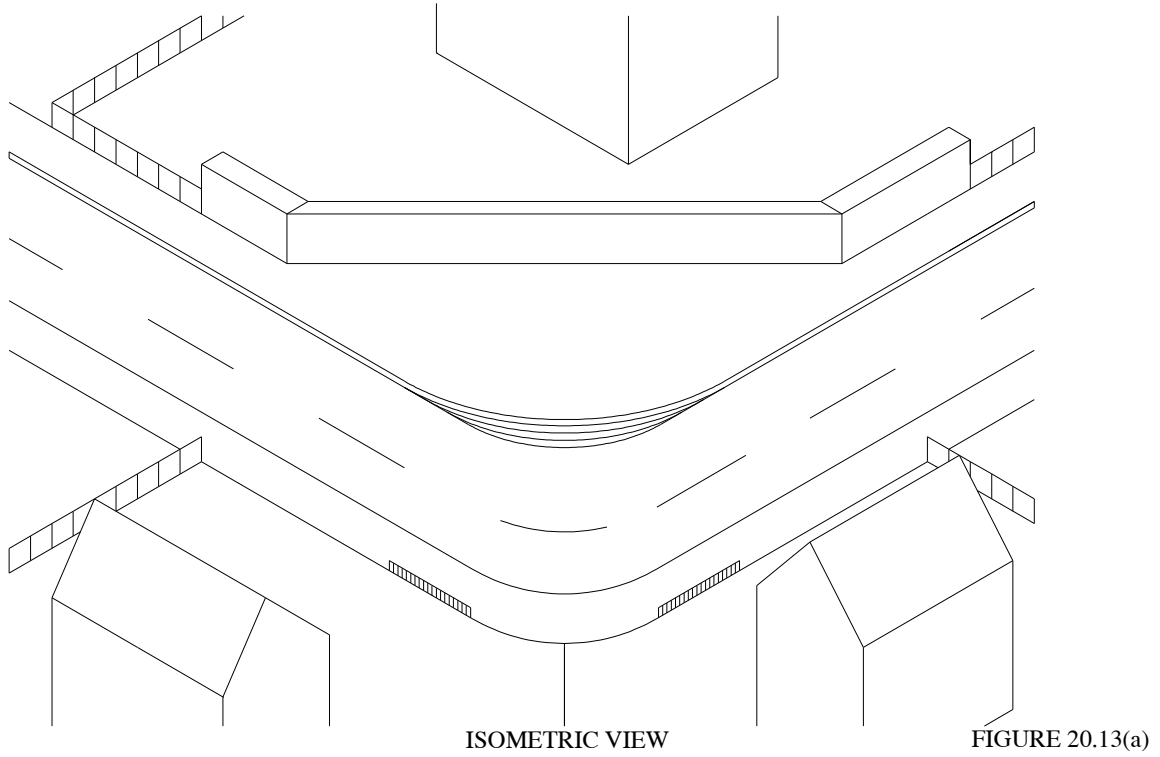

FIGURE 20.13 - SPEED BEND

Figure 20.14: Lateral Shift in Alignment 

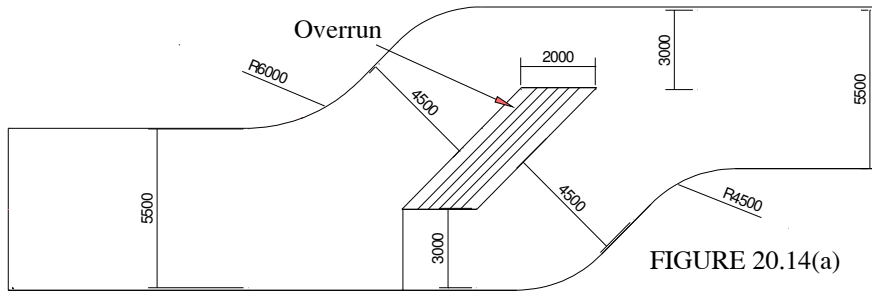

FIGURE 20.14(a)

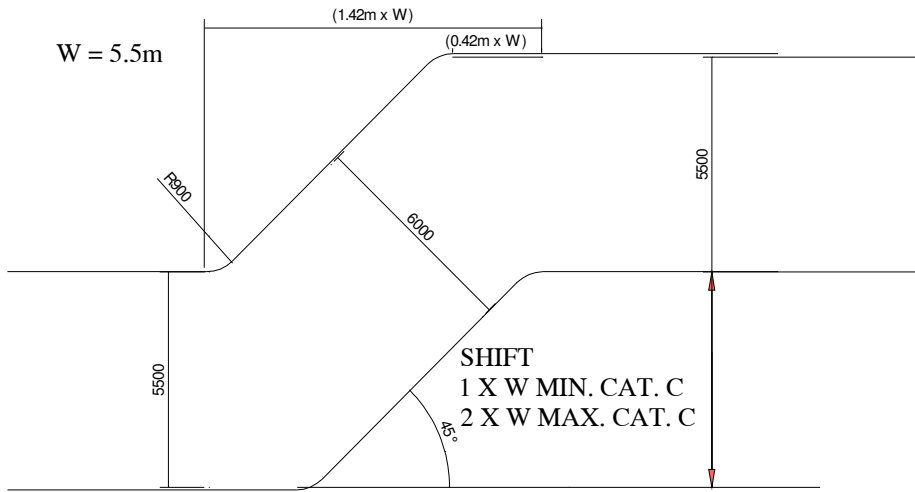

FIGURE 20.14(b)

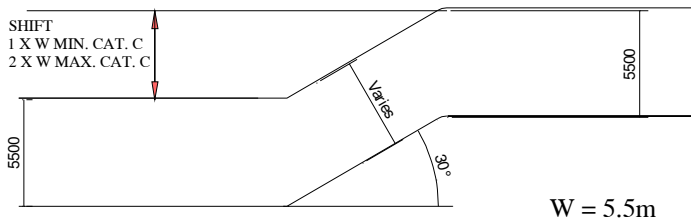

FIGURE 20.14(c)

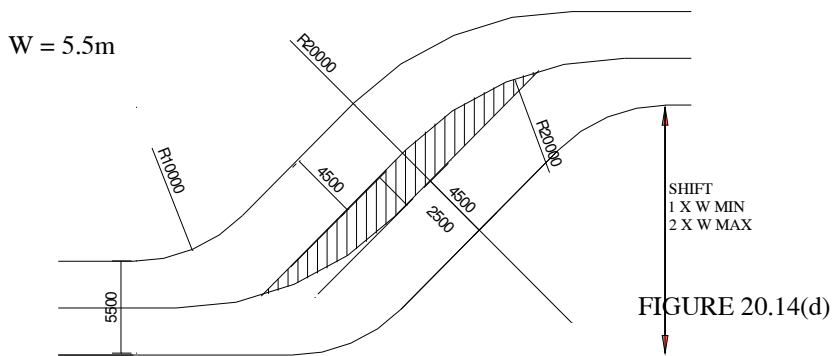
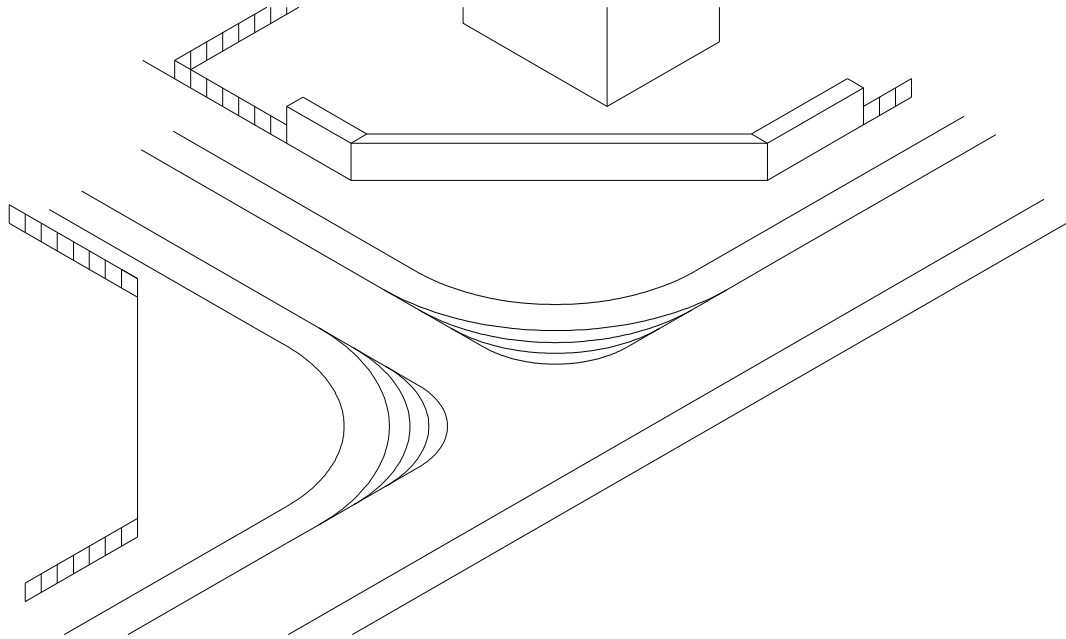

FIGURE 20.14(d)

FIGURE 20.14 - LATERAL SHIFT IN ALIGNMENT



ISOMETRIC VIEW

FIGURE 20.15(a)

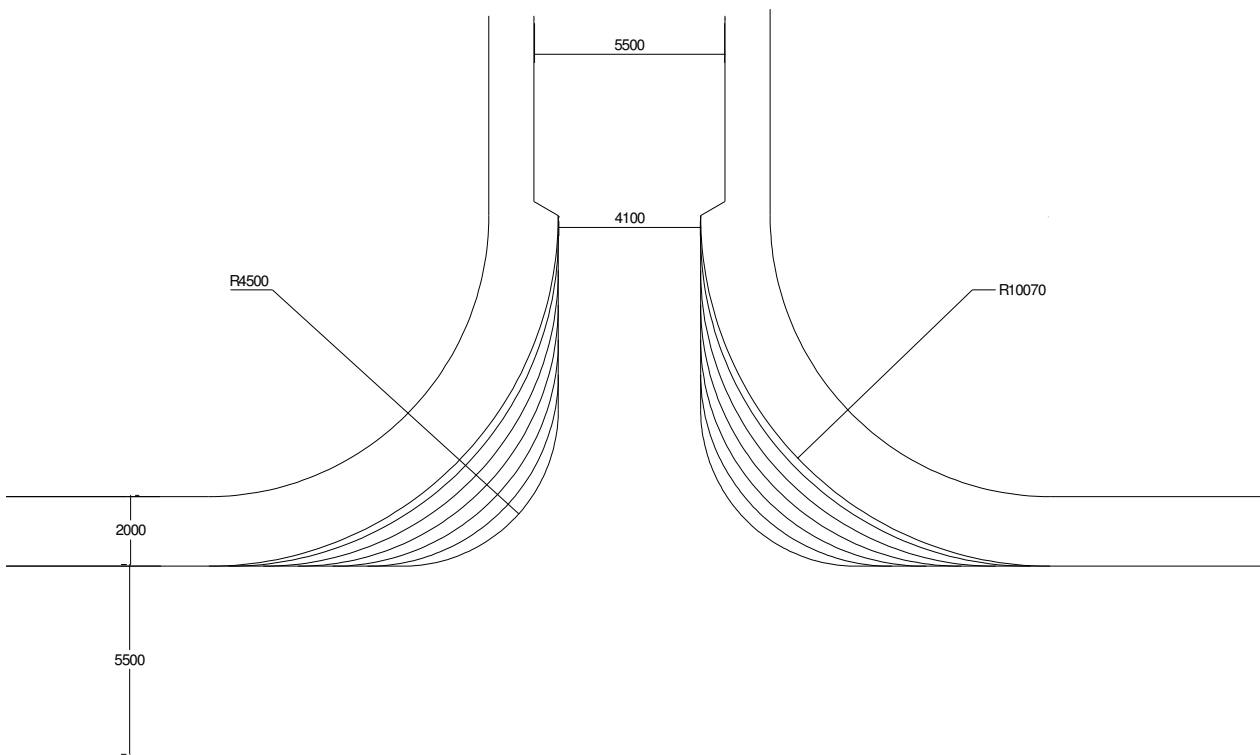

PLAN VIEW  
SCALE 1:200

FIGURE 20.15(b)

## FIGURE 20.15 - OVERRUN CORNERS

## 21. Provision for Pedestrians

### General

21.1 (a) Pedestrian movements should be made as convenient, safe and pleasant as possible by careful attention to the design and layout of pedestrian routes. The usage dictates the width and the degree of segregation.

(b) Features which will generate or attract pedestrian traffic such as shopping areas, schools, bus routes, car parks, clinics and parks should be identified at an early stage in the planning process. These will dictate the main spinal pedestrian routes which should be segregated as far as possible from major traffic routes and involve a minimum number of carriageway crossings.

(c) The design of facilities for pedestrians should take account of the requirements for accessibility set out in the Disability Discrimination Act 1995, its associated Code of Practice, and the recommendations in the Department for Transport publication “Inclusive Mobility”. This consideration should include access to public transport and to car parks to provide for integrated travel facilities.

**The Developer will be required to demonstrate compliance with the requirements of the Disability Discrimination Act by the provision of a Disability Access Statement.**

The benefits of providing an accessible environment go beyond those people meeting the definitions of disability in the Disability Discrimination Act to include others who are temporarily denied full mobility, such as a parent or carer pushing a pram, or a person recuperating from an illness. In these circumstances the simplest of journeys may involve a significant degree of extra effort or even pain, and the provision of suitable accessibility measures can significantly improve quality of life.

### Crossing Considerations



21.2 Particular attention should be paid to the location at which pedestrian routes cross carriageways. The choice of location should ensure that pedestrians are not exposed to unappreciated dangers. The appropriate use of hard and soft landscaping techniques can guide pedestrians to suitable crossing locations and help to prevent children running directly onto the carriageway. Careful consideration should be given to the location of pedestrian traffic generators, such as shops and leisure facilities, and the pedestrian routes should be designed to ensure there is an element of control over the locations where pedestrians will cross the carriageway.

- At Grade Pedestrian Crossings **A**
- 21.3 At designated pedestrian crossing points, other than those at which a suitable grade separated facility is provided, kerbs must be dropped as shown in Figure 25.4 to permit easy access to and from the carriageway for pedestrians with prams and wheelchairs.
- Grade Separated Pedestrian Crossings **A**
- 21.4 Where both pedestrian and vehicular traffic flows are very high it may be appropriate to consider underpasses or footbridges as carriageway crossings. These facilities should be designed in such a manner as to be more appealing to use than any other alternative route. The successful location of such facilities will require careful consideration to meet the aspirations for a fully accessible built environment.
- Controlled Pedestrian Crossings **A**
- 21.5 Where grade separation cannot be justified or provided it may be necessary to consider the use of controlled pedestrian crossing facilities. E.g. a pelican or zebra crossing. In considering the appropriate form of crossing reference should be made to the Aberdeenshire Council assessment criteria, based on predicted pedestrian and traffic flows. A tactile surface should be provided on the approach to all controlled crossings and further guidance on the layout of tactile slabs is available in the Department for Transport's Guidance on the Use of Tactile Paving Surfaces.
- In addition to this a high skid resistant surfacing material should be used on the approaches to any controlled crossing. Further guidance on this matter should be sought from the Local Roads Authority's Representative.
- Possible Enhancements to at Grade Pedestrian Crossings **A**
- 21.6 Uncontrolled at grade crossings may be required where flows do not justify the provision of grade separated or controlled crossings. This type of crossing may be improved by the inclusion of a traffic calming feature which makes it easier for pedestrians to cross the road. On all routes of Distributor Road classification or higher, tactile paving must be incorporated into the design of the crossing point, in accordance with the Department for Transport's Guidance on the Use of Tactile Paving Surfaces. Tactile paving should be used, on all road classifications, at crossing points where the crossing is perpendicular to the main pedestrian flow, i.e. a pedestrian refuge.
- Routes on Distributor Roads **A**
- 21.7 Where pedestrian routes of necessity run beside Distributor Roads, they shall be separated from the carriageway by a verge at least 2 metres wide (Para 31.3 and 31.6) in the interests of road safety and of improving the environment of the road.

Footway Widths **A**

21.8 The general width of footways is set out in Section 15. These widths may require to be increased to cater for high pedestrian volumes. Conversely, at the discretion of the Local Roads Authority's Representative, footways may be reduced in width over short lengths not exceeding 3 metres to negotiate mature trees and other obstructions, but they shall at no point be less than 1.4 metres wide. Where Statutory Undertakers' services are contained in the footway, special arrangements may be necessary at sections of reduced width.

Vehicular Footway Crossings **A**

21.9 Where vehicular access is taken across a footway, the ramp will be confined to the front portion of the footway, thus emphasising pedestrian priority. The reduced length of ramp also helps to encourage a reduction in the speed of vehicles crossing the footway.

Gradients **A**

21.10 Gradients on both footways and footpaths should not normally exceed 5.5 per cent. Steeper gradients require the specific approval of the Local Roads Authority's Representative, but these sections will be considered as ramps and the criteria set out in Section 21.12 will be applied.

Baffle Barriers **A**

21.11 Situations where long lengths of public footpath meet a road at right angles should be avoided because of the inherent dangers of children moving at speed towards the road ahead. Where the situation is unavoidable, pedestrian guardrails or baffle barriers should be considered and incorporated into the layout at the design stage. The barriers need not be in railing form but should be constructed in a way that is compatible with their surroundings and agreed with the Local Roads Authority's Representative. Where a railing is proposed it should normally be constructed of tubular galvanised steel. An alternative may be acceptable at the discretion of the Local Roads Authority's Representative.

Dimensions will vary according to the site but a typical layout would be as shown in Figure 21.1. In situations where the footpath is bounded by open areas on its approach to the road, consideration should be given to additional means of restraint within the open areas, such as suitably placed prickly shrubs or suitably positioned lengths of guardrail to channel pedestrians through the baffle barriers. If baffle barriers are to be used access for maintenance vehicles must be provided.

Ramps and Steps **A**

21.12 Pedestrian ramps and steps shall comply with the geometric standards and recommendations set out in the Department for Transport publication "Inclusive Mobility".

Disabled Access  
to Buildings 

- 21.13 For disabled access to buildings ramps should be incorporated off road. Where this is not practicable the Local Roads Authority's Representative should be consulted to discuss options for formation of access ramps on the footway.

Reference should be made to the Technical Standards (Scotland) Buildings Regulations and the Institution of Highways and Transportation publication "Guidelines for Reducing Mobility Handicaps" for further details of required provision.

Obstacles to  
Pedestrian  
Routes 

- 21.14 Any street furniture, which is to be provided, such as planters and waste paper bins, should be located in such a way as to maintain a 2 metre wide obstacle free footway.

Not only is this required to facilitate pedestrian movement but is also required to allow mechanised maintenance.

Figure 21.1: Typical Baffle Barrier Layout 

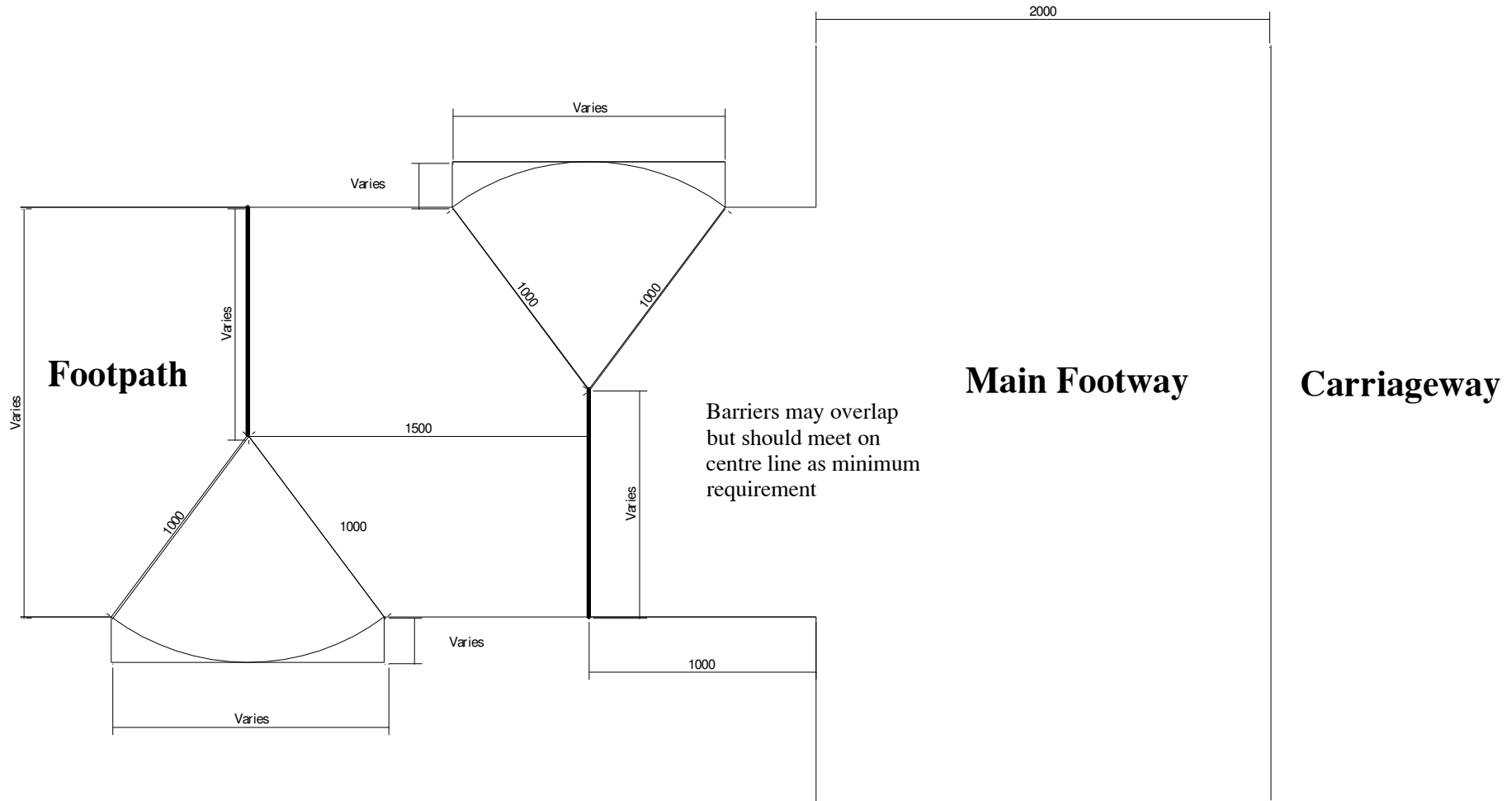

FIGURE 21 .1 - TYPICAL BAFFLE BARRIER LAYOUT

## 22. Provision for Cyclists

### General

- 22.1 A cycle network should be established to cater for the needs of cyclists. The network should link residential areas to shopping areas, schools, bus routes, clinics, parks etc.

In residential areas, where 20mph speed limits exist, separate cycle facilities will not normally be required. At this reduced speed cycles and vehicular traffic can safely share the same carriageway space.

The Developer will be required to provide a Cycle Audit to demonstrate that the full needs of cyclists have been considered in the overall design of the Construction Consent.

It should be noted that combined footways/cycletracks will require to be the subject of a formal Traffic Order and signed in accordance the current version of The Traffic Signs Regulations and General Directions. The Developer will be liable for the costs associated with the required Traffic Order and route signage.

### Objectives

- 22.2 The cycle network should meet the following main objectives:

- i) Cyclists should be segregated from large volumes of vehicular traffic, especially where vehicle speeds are in excess of 40mph.
- ii) Vehicle speeds should be reduced where there are large volumes of cyclists.
- iii) Safe crossing points should be provided for cyclists at roads with high traffic flows.

Further advice can be obtained from the Institution of Highways and Transportation Guidelines “Cycle-friendly Infrastructure – Guidelines for Planning and Design”.



22.3 In order for cycling routes to be safe, convenient and attractive the following five criteria should be considered and met:

- Coherence:** The cycling infrastructure should form a coherent entity, linking all significant trip origins and destinations, routes should be continuous and consistent in standard.
- Directness:** Routes should be as direct as possible, based on desire lines- detours and delays will deter use.
- Attractiveness:** Routes must be attractive to cyclists on subjective as well as objective criteria: Lighting, personal safety, aesthetics, noise and integration with the surroundings are important.
- Safety:** Designs should minimise casualties and perceived danger for cyclists and other road users.
- Comfort:** Cyclists need routes that are smooth, with well maintained surfaces, flush kerbs, regularly swept, and with gentle gradients; routes must be convenient to use and avoid complicated manoeuvres and interruptions.



22.4 As stated earlier a Cycle Audit will be required with each Construction Consent application.

Cycle Audits should be carried out in accordance with “Guidelines for Cycle Audit and Cycle Review”, published by the Institution of Highways and Transportation, 1998.

All new developments should be considered to carry a Cycle Friendly classification in accordance with the above guidelines. In most cases it will be appropriate for CAP3 and CAP4 audits to be carried out.

For larger developments the Local Roads Authority’s Representative may require a CAP 1 audit to be provided as part of any Traffic Impact Assessment.

Early consultation with the Local Roads Authority’s Representative is essential in this matter

Definitions **A**

22.5 The following definitions apply to cycling facilities:

- i) A cycle track has the same meaning as described in the Roads (Scotland) Act 1984. It is therefore a “road” for cyclists or cyclists and pedestrians segregated from the carriageway.
- ii) A cycle lane is a lane provided for cyclists within a carriageway.

A cycle route is a combination of these facilities.

Format **A**

22.6 In most circumstance the appropriate format of cycle track will be of the shared use type. It is also anticipated that most cycle tracks will comply with the requirements of un-segregated cycle tracks. To allow the free movement of cyclists and pedestrians the shared facility will be 3.0metres wide with at least a 0.5m buffer zone between it and the carriageway.

If a segregated facility is required it should meet the standards set out in Table 22.1

Table 22.1 – Cycle Track Widths

Boundary conditions	Segregated			Shared
	Footway/ Footpath	Cycletrack	Verge	
Open site	1.2m	1.3m	-	2.5m
Walls, bushes	1.2m	1.5m	-	2.7m
Carriageway	1.2m	1.5m	0.5m	3.2m





Signing **A**

22.7 Signing will require to be erected on any cycle network. Early contact should be made with the Local Roads Authority’s Representative to determine the exact provision required. All signing must comply with the current version of the Traffic Signs Regulations and General Directions.

Surface **A**

22.8 Surfacing for a shared use facility may be of a standard footway construction according to the developer's intended footway material.

**NB** conventional or small element slab construction is not suitable for shared use.

- Junctions 
- 22.9 Kerbs must be dropped at crossing points. Where a signalled controlled crossing facility is required on a shared use facility a TOUCAN crossing should be considered. Consideration should be given to the priority at intersections between cycle tracks and roads. It may be appropriate for the cycle track to have right of way in certain circumstances. Reference should be made to current good practise guides for further information on this particular aspect.
- Parking 
- 22.10 Parking facilities for cyclists should be secure and convenient otherwise they will be underused and cycles will be parked in a haphazard fashion. Devices to support cycles should be appropriately located to minimise damage and maximise security against theft and vandalism. Currently the favoured style of cycle stand is the Sheffield, Figure 22.1, although other forms will be considered. Parking standards for bicycles should be as detailed in the current version of Car Parking Standards for Development Control in Aberdeenshire.
- Lighting 
- 22.11 Lighting shall be installed on combined footpaths/cycletracks to comply with the requirements of BS 5489: Part 9, Section 3, Clause 14 and lighting levels shall be as specified in Table 6 of that standard.
- Traffic Orders 
- 22.12 It should be noted that combined footways/cycletracks will require to be the subject of a formal Traffic Order and signed in accordance the current version of The Traffic Signs Regulations and General Directions. The Developer will be liable for the costs associated with the required Traffic Order and route signage.

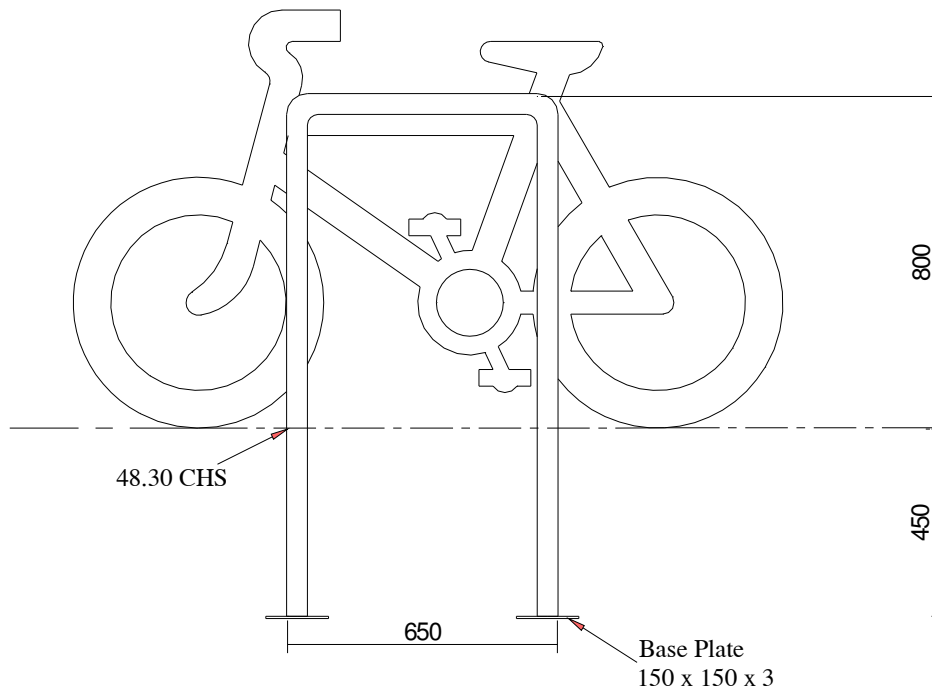
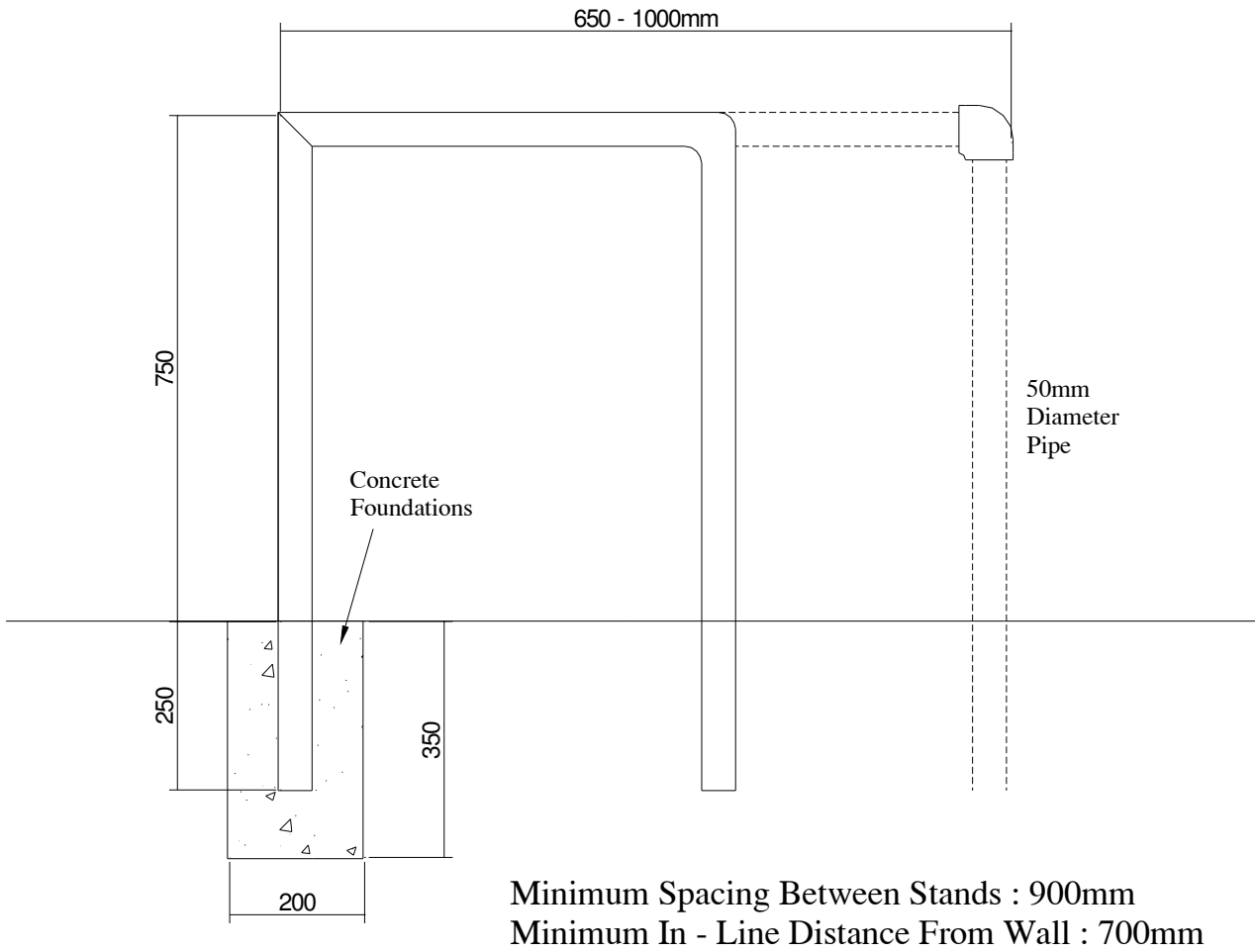





Figure 22.1 - 'Sheffield' Cycle Racks

## 23. Rural Areas

- Introduction  23.1 This guide is predominately targeted at the urban development situation and its immediate environs. Areas of a rural nature require to be considered somewhat differently.
- Hierarchy  23.2 Circumstances when rural standards may be applied should be discussed at an early stage, and may include:
- i) Developments from an unrestricted road;
  - ii) Developments which are likely to remain remote from the existing settlement for the foreseeable future.



Rural areas can be treated as having a similar hierarchy as to the urban areas. However the increased traffic speeds on unrestricted roads should be regarded as a significant factor and care must be taken to ensure that adequate visibility is provided to take account of this.

- Road width  23.3 Within this document road widths have been specified to take account of the likely traffic generated by the development. This basic premise will hold for rural development except the restrictions on overall length of road will be relaxed.

Using this method Table 23.1 below indicates alternative road widths based on number of dwellings:

Table 23.1 - Road Widths

< 15 dwellings	3.5m single track access road with passing places
> 15 dwellings	5.5 metre wide carriageway

- Development on Existing Roads  23.4 Where a development is proposed on a road which does not meet these criteria then the developer will be required to widen the road along the frontage of the development or the access road to the development to the appropriate width.
- Passing Places  23.5 All passing places in rural areas should be constructed to the dimensions given in Figure 23.1. All passing places must be intervisible and up to a maximum of 150 metres apart. The Developer will be responsible for signage in accordance with the current version of the Traffic Signs Regulations and General Directions

23.6 Visibility splays are calculated in the same manner as that used in the Urban area for the X distance (Section 18.9), however the speed on which the Y distance is based will be higher. In certain circumstance the design speed for the road will not be known and it may be necessary for actual speeds to be recorded at the site to allow the Y distance to be calculated. For more information reference should be made to the current version of the Design Manual for Roads and Bridges.

In the absence of sound design speed information, or actual 85%ile speeds, the details in Table 23.2 should be used as a guide. In some circumstances the Local Roads Authority’s Representative may require actual 85%ile speeds to be recorded on site before consent is granted.

Table 23.2 - Speed Limit – Y Distance

Speed Limit (mph)	70	60	50	40	30
Y Distance (m)	295	215	160	120	90

Figure 23.1: Typical Passing Place Detail 

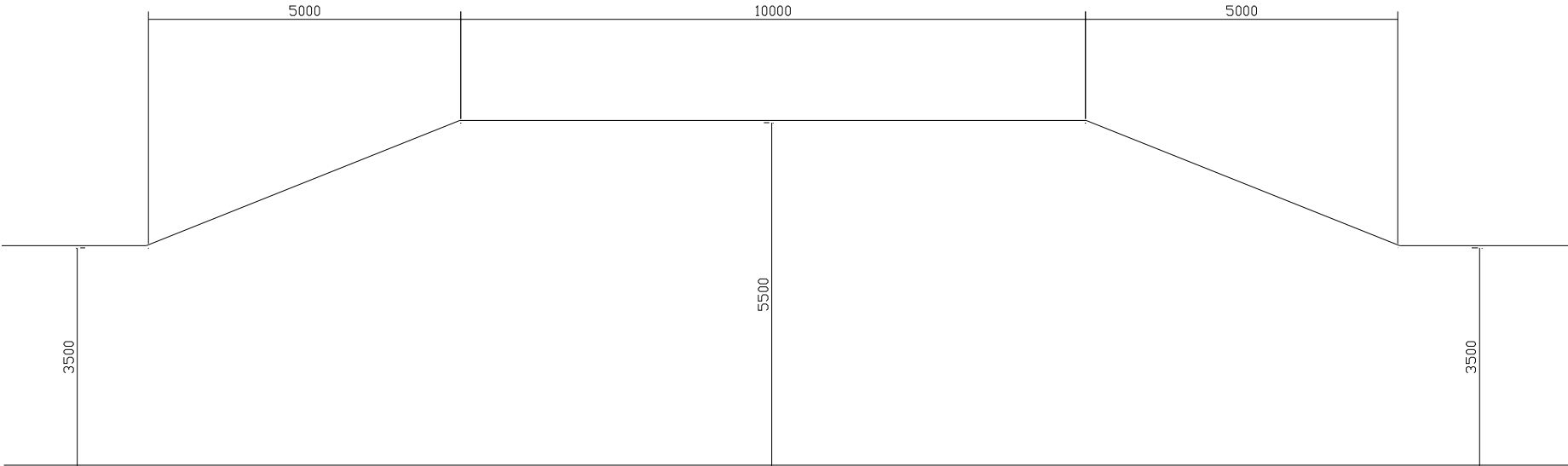

Figure 23.1 - Typical Passing Place Detail

## 24. Making Up and Adoption of Private Roads

### Introduction

- 24.1 In accordance with the terms of the Roads (Scotland) Act 1984 the Local Roads Authority is required to maintain a list of roads for which they have the responsibility of management and maintenance, the Statutory List of Public Roads. Section 151 of the Act refers to these roads as “Public Roads”.

“Private Roads” are any way over which there is a public right of passage, other than a Public Road.

### Additions to the Statutory List of Public Roads

- 24.2 Provision is contained within The Roads (Scotland) Act 1984 for Private Roads to be added to the Statutory List of Public Roads. The provisions are outlined in Sections 1(4), 16 and 17(3)(c)(iii).

Any road to be considered for addition to the Statutory List must be completed to the standard required by the Local Roads Authority for that particular classification of road. This assessment will also take into account the urban or rural nature of the surrounding locus.

### Request for Addition to the Statutory List

- 24.3 An application can be made to the Local Roads Authority for a Private Road to be adopted, i.e. added to the Statutory List of Public Roads. Once the statutory procedures have been successfully completed the road will become a Public Road and become the responsibility of the Local Roads Authority for management and maintenance.

Such an application must be supported by “the requisite number” of frontagers. The “requisite number” of frontagers is defined “as a majority or such number as together owns land which includes not less than half the boundary between the land fronting or abutting the relevant road and that road” Further guidance on this can be found in The Roads (Scotland) Act 1984, Section 1(7), as amended by the Abolition of Domestic Rates Etc (Scotland) Act 1987, Schedule 6.

The Local Roads Authority must be satisfied that the application has the support of the requisite number of frontagers and may take steps to ascertain this.

### Section 13 Notice

- 24.4 Following a competent request for adoption the Local Roads Authority will carry out an inspection of the road to ascertain if it is constructed to the required standard.

If this inspection shows that it is to the required standard the road will be added to Statutory List of Public Roads within 12 months of a competent application.

However, if this inspection shows that works are required to bring the road up to the required standard the Local Roads Authority will issue a notice under The Roads (Scotland) Act 1984, Section 13 (a Section 13 Notice) to the frontagers.

A Section 13 Notice **requires** the frontagers to make up the road to the required standard. The notice will specify the following:

- 1) The Local Roads Authority's estimate of the cost of the required works
- 2) A scheme apportioning the cost among the frontagers. The scheme must be equitable in the opinion of the Local Roads Authority and it must describe for each frontager the proportion of the costs to be paid by him
- 3) The dates by which the works shall be commenced and completed.

If the terms of the notice are not met the Local Roads Authority has the power to carry out the works or complete any unfinished works. The expenses incurred by the Local Roads Authority are recoverable in accordance with the terms of the Section 13 Notice.





- |   |  |
|---|--|
| Appeals Against a Section 13 Notice  | 24.5 Any person receiving a Section 13 Notice may appeal by summary application to the sheriff within twenty-eight days of the date of service of the notice. The sheriff's decision is final.   |
| Maintenance Period                   | 24.6 Once the road is in a condition acceptable to the Local Roads Authority it must be added to the Statutory List of Public Roads within twelve months.  |
| Required Standards                   | 24.7 The required standards for the road to be adopted will be set out in the Section 13 Notice. In general terms the road shall comply with the standards set out in the Tables below. It should be noted however that the Local Roads Authority's Representative has discretion to relax these conditions to take account of local factors relating to the road in question. |
| Required Surface Condition           | 24.8 The surface must be in good condition and free from potholes or any major surface deterioration. If this is not the case the surface will require to be renewed and the Section 13 Notice will include for the cost of any such repairs.  |

Table 24.1 Adoption Criteria - Urban Private Roads 

<b><u>Feature</u></b>	<b><u>Standard</u></b>	<b><u>Comment</u></b>
Carriageway Width	5.5m	May be reduced at the discretion of the Local Roads Authority's Representative, if traffic flows are very low.
Minimum Camber/Crossfall	2.5%	
Maximum Gradient	5.5%	May be increased over short lengths at the discretion of the Local Roads Authority's Representative.
Minimum Gradient	0.8%	Minimum practical for drainage channels.
Minimum Vertical Curve Length	$K \times \text{algebraic difference in \% gradient}$	Where $K = 3$ ; absolute minimum length = 15m.
Minimum Horizontal Curve Radius	15m	Except speed control bends. Superelevation not essential.
Minimum Sight Distance	35m	Further reduction may be allowable if it can be determined that speeds will be lower. Refer to DB32.
Junction Visibility	See Table 18.1	See Section 18 for relaxations.
Turning Area	Provision as outlined in Section 19 will be required.	
Footways	2m	On both sides. Possible relaxation to 1.8m on one side, or in exceptional circumstances no footway, allowing a shared surface approach, only at the Local Roads Authority's Representative's discretion.
Drainage	Comply with Section 31 of this guide.	Minimum requirement is a system to remove standing water from the carriageway surface.
Lighting	Comply with Section 32 of this guide.	At the discretion of the Local Roads Authority's Representative.

Table 24.2 Adoption Criteria – Rural Private Roads (Unrestricted Speed Limit) 

<b><u>Feature</u></b>	<b><u>Standard</u></b>	<b><u>Comment</u></b>
Carriageway Width	3.5m with intervisible passing places	Widening on bends required, see Section 17.
Minimum Camber/Crossfall	2.5%	
Maximum Gradient	5.5%	May be increased over short lengths at the discretion of the Local Roads Authority's Representative.
Minimum Gradient	0.8%	Minimum practical for drainage channels.
Minimum Vertical Curve Length	$K \times$ algebraic difference in % gradient	Where $K = 10$ ; absolute minimum length = 30m.
Minimum Horizontal Curve Radius	180	Reduced radii may be considered.
Minimum Sight Distance	70m	Further reduction may be allowable if it can be determined that speeds will be lower. Refer to DB32.
Junction Visibility	4.5m x 215m	See Section 18 for relaxations.
Turning Area	Provision as outlined in Section 19 will be required.	
Verge (Footway where appropriate)	2m	Both sides. Possible relaxation to 1.0m verges at the Local Roads Authority's Representative's discretion.
Drainage		Offlets and soakaways as a minimum.
Lighting		Would not normally be required in rural areas.

## 25. Vehicular Access to Premises and Servicing Arrangements

### Access to Premises

25.1 Vehicular access to residential and minor commercial premises will normally be taken from the public road via a footway crossing designed to cater for the traffic volume and maximum weight of vehicle anticipated (Sections 30.22 and 30.23). For major commercial and industrial development, however, access should be by means of "service roads" connecting to the main road network at a T-junction designed as detailed in Section 18. In the case of larger retail warehouses, supermarkets and superstores, it is essential for service access to be segregated from access to customers' parking areas in the interest of operational convenience and of safety.

### Service Roads

25.2 Service roads shall be designed to at least INDUSTRIAL ACCESS ROAD standards (Section 11), with particular attention to widening on small radius bends (Section 17) and turning areas (Section 19).

### Driveways

25.3 Private driveways should normally meet the road at right angles and be at least 15 metres from the nearest junction along the secondary road. Driveways should be positioned to enable the required visibility standards to be achieved. A crossing of the footway will be required and this should be constructed in accordance with Figure 25.3.

A 3 metre length beyond the paved road areas should be paved to prevent deleterious material (e.g. loose chippings) being carried on to the road. In rural areas this may be required to be extended to 5-10 metres (at the discretion of the Local Roads Authority's Representative). Severe gradients, which render driveways unsuitable for car parking, should be avoided wherever possible (1 in 20 desirable). Driveways must be internally drained.

House driveways should be providing a hardstanding of sufficient size to provide the parking provision detailed in the current version of "Car Parking Standards for Development Control in Aberdeenshire". Should garage facilities be provided within the site this length may be reduced accordingly. For new properties a minimum length of 6.0metres should normally be used to allow for an adequate parking space for one vehicle in front of a garage, this may be reduced to 5.5 metres in certain circumstances. For existing properties a minimum length of 5.0 metres should be used.

### Service Areas

25.4 Service areas range from single parking bays for delivery vehicles to sophisticated structures incorporating loading bays and mechanical goods handling equipment. The size and layout of all service areas should be such that all vehicles enter and leave in a forward gear and do not need to reverse on the public road to turn round. A maximum gradient of 4% shall also be maintained over an 8 metre length from the junction.

25.5 Where vehicles are to be loaded or unloaded while parked parallel to the kerb in service roads, parking bays 3 metres wide and at least 3 metres longer than the vehicles using them, should be clearly marked out and the width of the service road should be increased as detailed in Table 25.1.

Table 25.1 – Service Road Widths for Kerbside Loading

Description of Service Road	Two-Way Working	One-Way Working
Loading Bays on one side only	9.0m	6.5m
Loading Bays on both sides	12.0m	9.5m

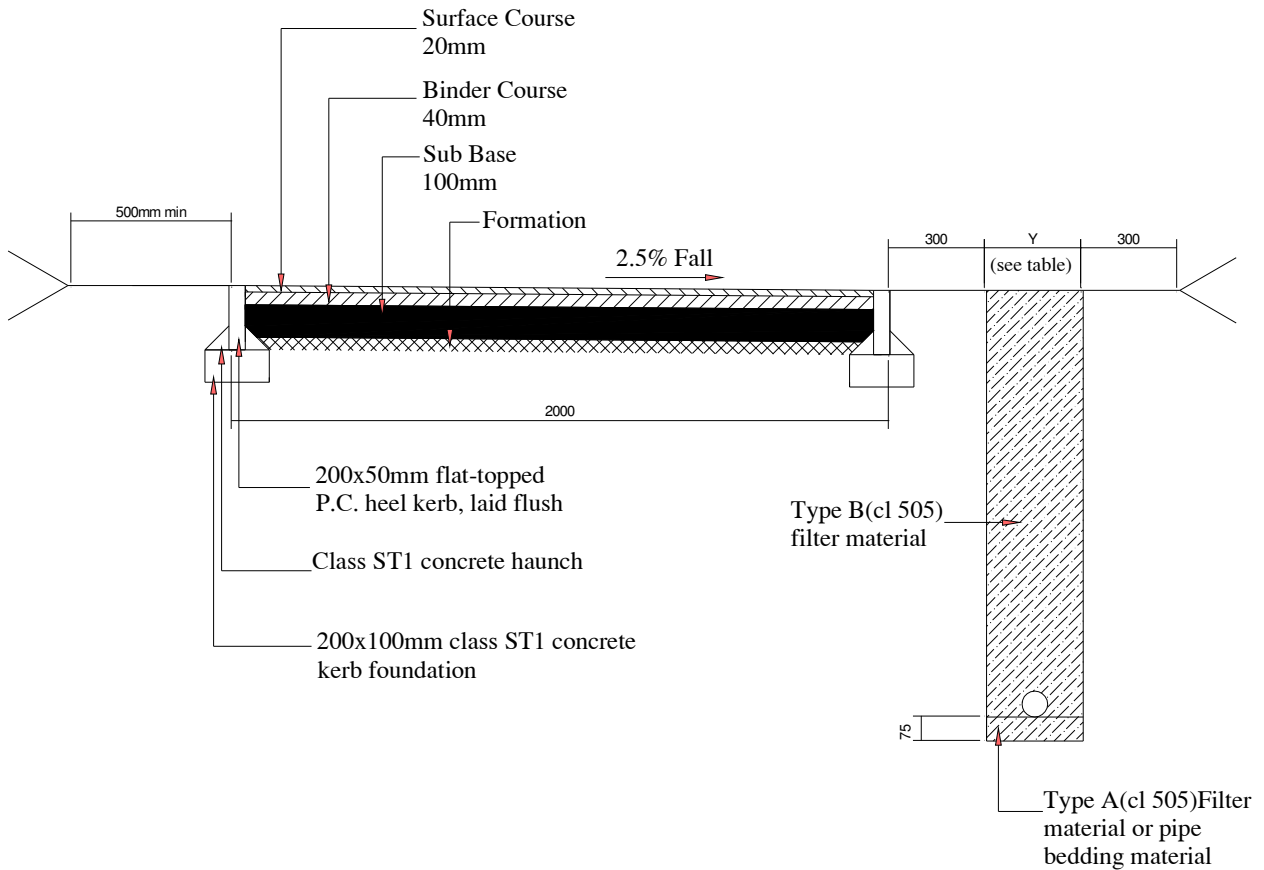

MINIMUM DRAIN WIDTH - Y

$Y = X + 300\text{mm}$  for drains not exceeding 1.5m depth

$Y = X + 450\text{mm}$  for drains exceeding 1.5m depth

X = Drain Diameter

(depth below finished level)

FIGURE 25.1

FIGURE 25.1 - TYPICAL FOOTPATH CONSTRUCTION

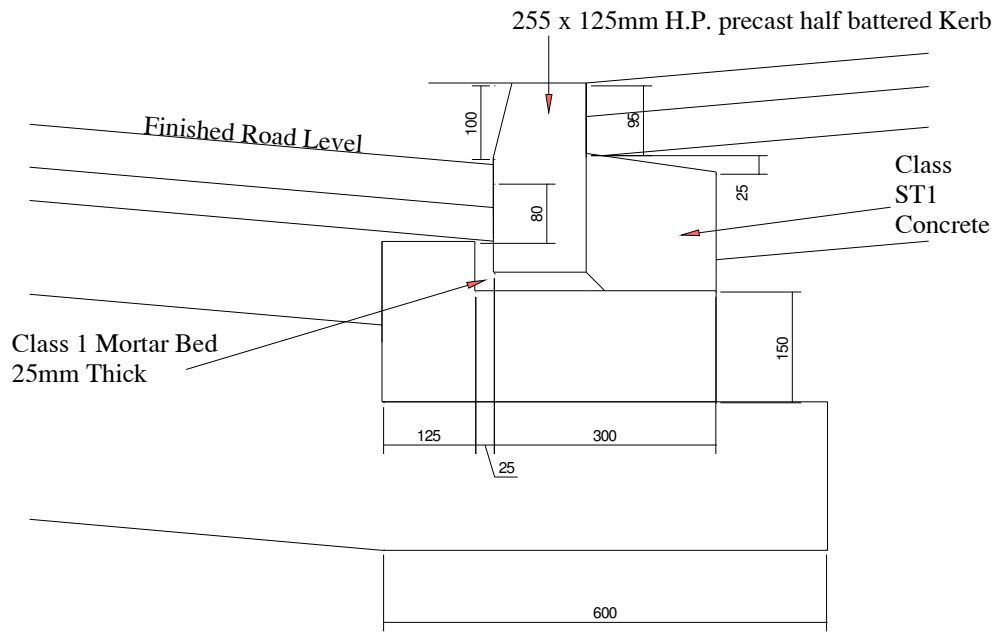

Type 1

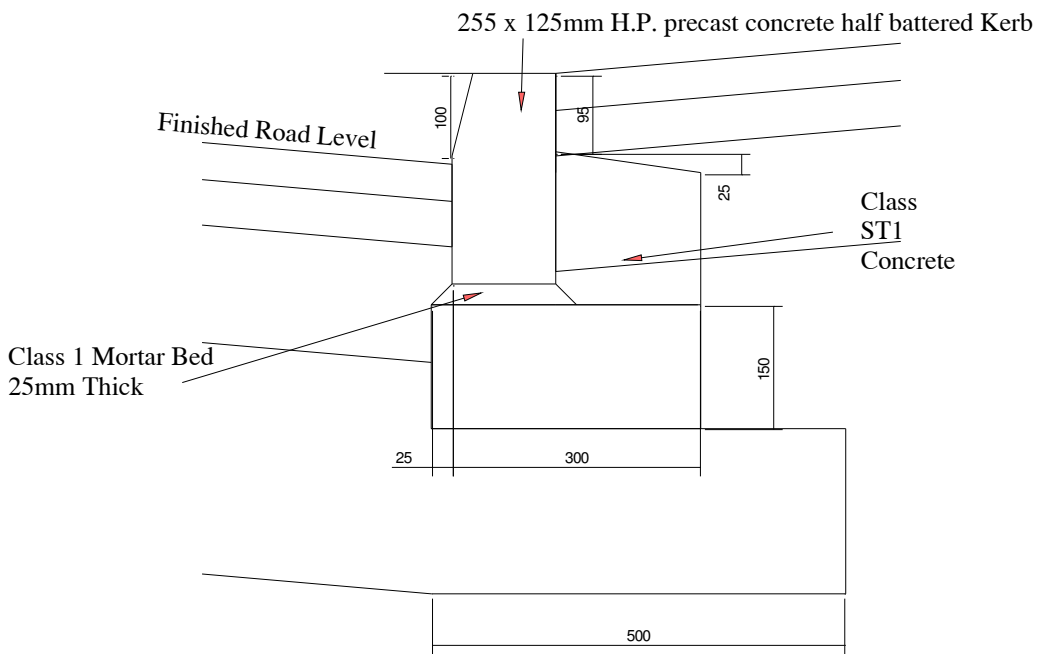

Type 2

Figure 25.2 - Kerb Details

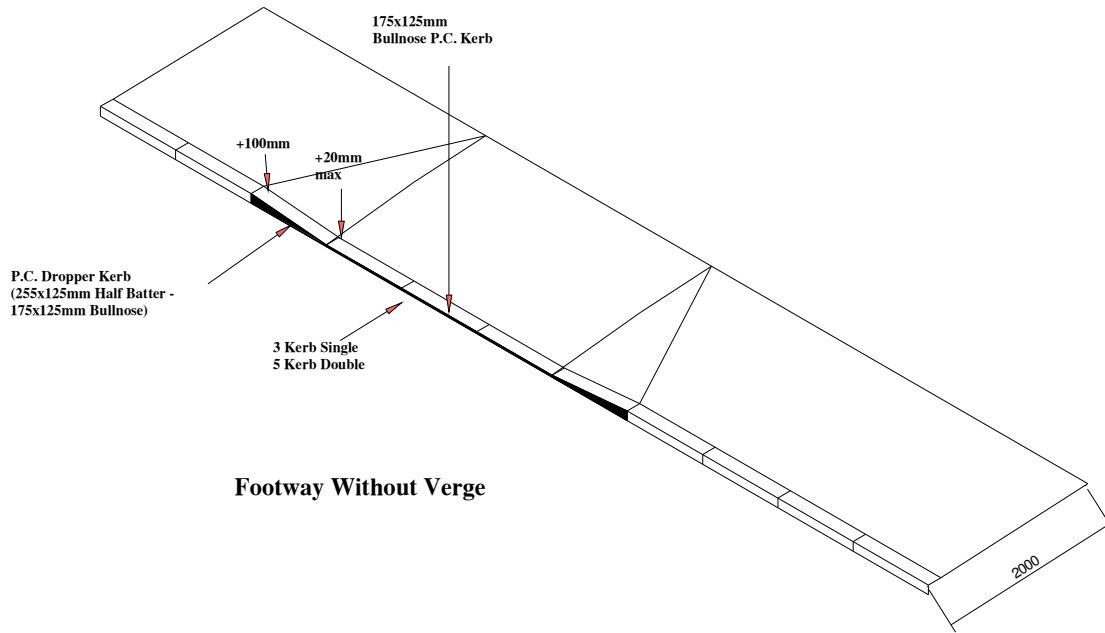

Figure 25.3 (a)

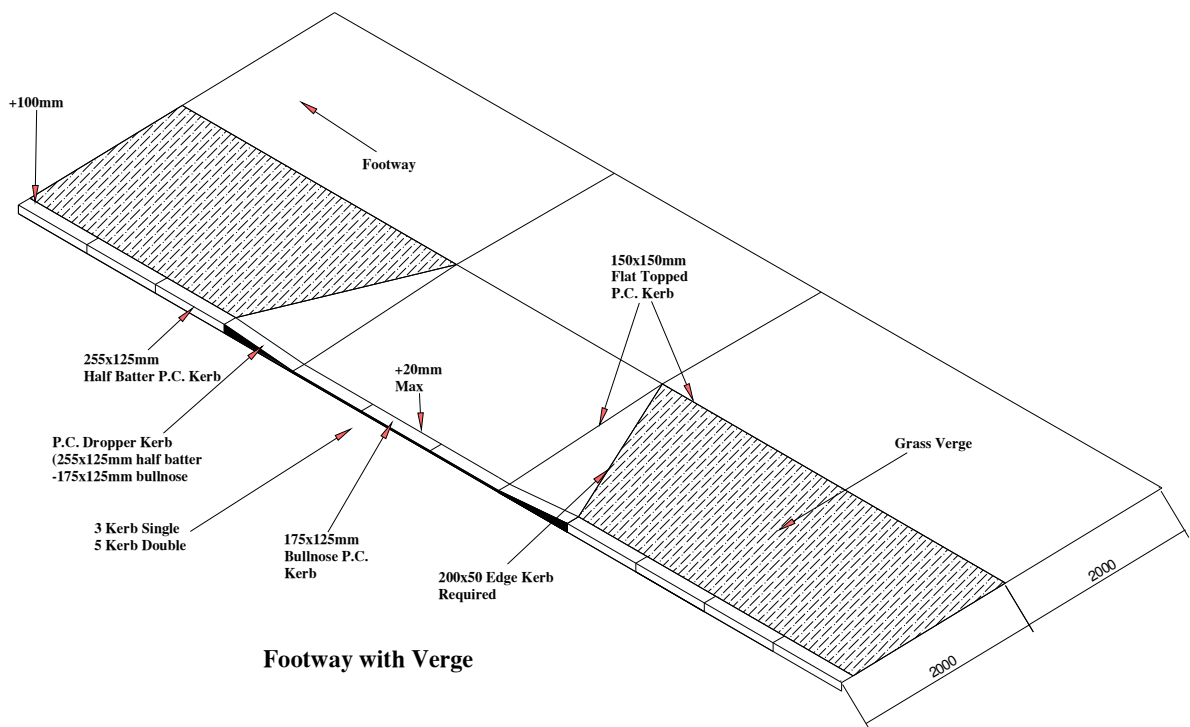

Figure 25.3 (b)

## FIGURE 25.3 - VEHICULAR FOOTWAY CROSSINGS

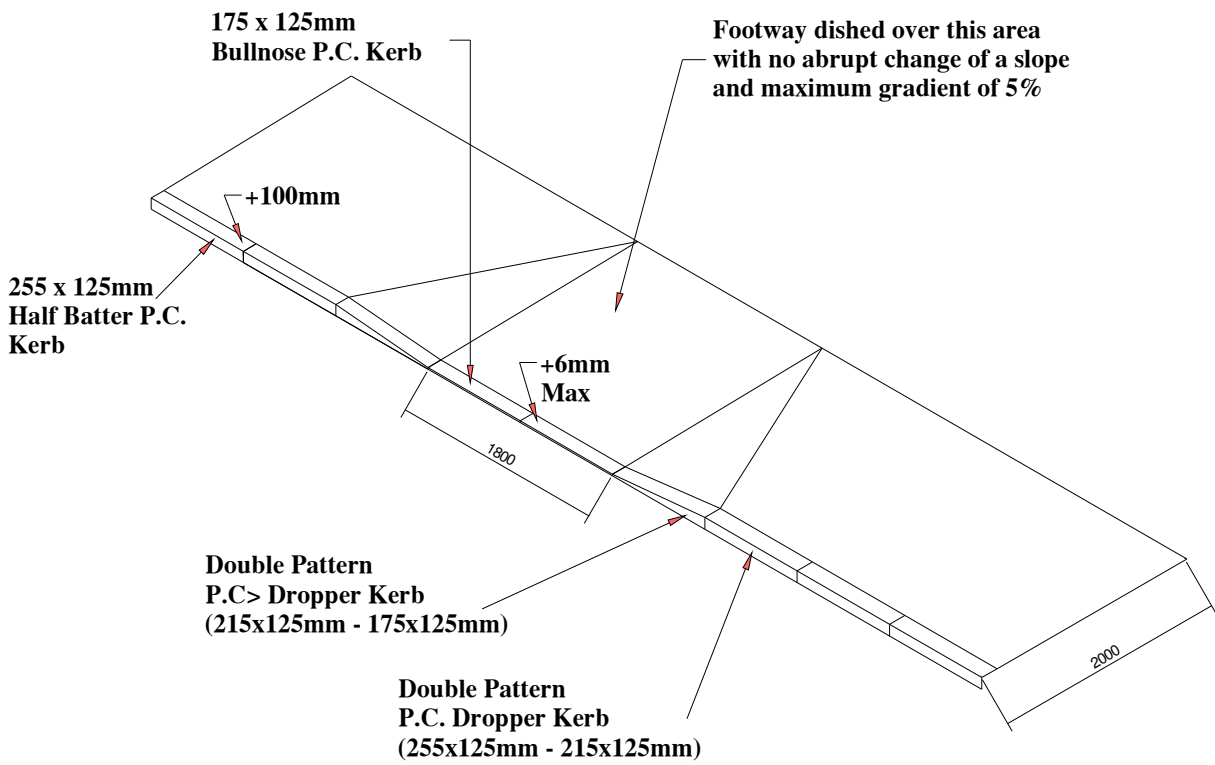







Figure 25.4

## FIGURE 25.4 - DROPPED KERB DETAIL AT DESIGNATED PEDESTRIAN CROSSING POINT

## 26. Car Park Provision

Level of Provision and Adoption Criteria 	26.1 In general, adequate off-road parking should be provided adjacent to all new developments to ensure that vehicles are not parked on the road where they may impede traffic flow and constitute a safety hazard. The levels of provision detailed in the current version of Car Parking Standards for Development Control in Aberdeenshire shall be used as a minimum requirement.  The suitability of parking areas for adoption will be determined in accordance with the guidance given in Section 3.4 of this guide.
Rehabilitation 	26.2 Whatever existing buildings are rehabilitated or modernised, the opportunity should be taken to provide parking at the level required for comparable new development. This may involve the selective demolition of certain derelict buildings, utilisation of former garden ground or some adjustment of road boundaries to create off-road parking areas.
Location 	26.3 The location of car parking areas in a development should be considered at an early stage in the design process to achieve a balanced distribution of spaces throughout the site, conveniently related to user destinations. Pedestrian access to premises should be so arranged that it is easier and more convenient to use the designated parking areas than to park casually on the road with special consideration given to the needs of disabled people.
Residents' Parking 	26.4 <b>Parking spaces reserved for the exclusive use of certain proprietors and/or their guests should be located within the property curtilage wherever possible.</b> This is most readily achieved by the provision of private driveways (Section 25.3) and/or individual garages/carports. Failing this, the location and surface treatment of off-road parking areas provided in lieu of the above should emphasise their private nature.
Visitors' Parking 	26.5 Parking areas provided for communal use by casual visitors should be located so as to be obvious to strangers to the development. It will often be appropriate for such public parking to be located in lay-bys, particularly since their presence can positively discourage indiscriminate kerbside parking elsewhere on the road. In general terms provision of 1 space per four dwellings should be sufficient, however further guidance on this can be sought from the Local Roads Authority's Representative.

Walking Distances 

26.6 Residents' parking spaces should be situated no more than 30 metres walking distance from the main entrance to the dwelling they serve, and the maximum distance for visitors' spaces should be similarly limited to 100 metres. Consequently, where lock-up garages are provided at some distance from the dwellings they serve, other off-road areas may be required for the convenient parking of residents' cars.

Bay Sizes 

26.7 The size of the standard car in the UK is approximately 4.75 metres x 1.8 metres. Allowing suitable clearances all round and for the opening of doors, the minimum design module for car parking bays shall be 5 metres x 2.5 metres with a 6m aisle. Longer bays will be required in certain situations (e.g. lay-bys).

Disabled Persons 

26.8 About 5% of parking should be reserved for disabled persons. The location and layout of parking spaces for disabled people should be designed in accordance with the recommendations in the Department for Transport publication "Inclusive Mobility".

Car Park Layouts 

26.9 Typical layouts for off-road parking areas are shown in Figure 26.1. It should be noted that angled parking layouts tend to be appreciably less efficient in land-use than 90° parking layouts even with the narrower aisle widths possible with single-way working. The use of angled parking may, however, be appropriate on narrow sites.

Large Car Parks 

26.10 In industrial, commercial and shopping developments, parking provision will normally be in the form of either large surface or multi-storey car parks. The layout will depend upon operational requirements, particularly where it is proposed to control entry and exit by means of barriers, with adequate space provided to ensure that any queues which develop do not extend on to the public road.

Access 

26.11 Vehicular access to off-road parking areas will normally be taken from the public road via a footway crossing (Figure. 25.3). However, for large car parks, liable to generate substantial traffic flows, access shall be taken via a road junction formed in accordance with Section 15. In such cases the car park access shall be constructed to CORE ROAD standards although a reduced width may be appropriate where one-way operation is to be enforced.

Lay-by Parking 

26.12 The layout of lay-by parking areas is dependent on the road type and the traffic flow: on CORE ROADS lay-by parking shall normally comprise bays, 6 metres long x 2.5 metres wide, located parallel to the carriageway and having 6m long splays at both ends.

Figure 26.1: Off Road Parking Areas 

Right Angled Parking (Dia = 90 DEG)  
Two-way circulation permitted

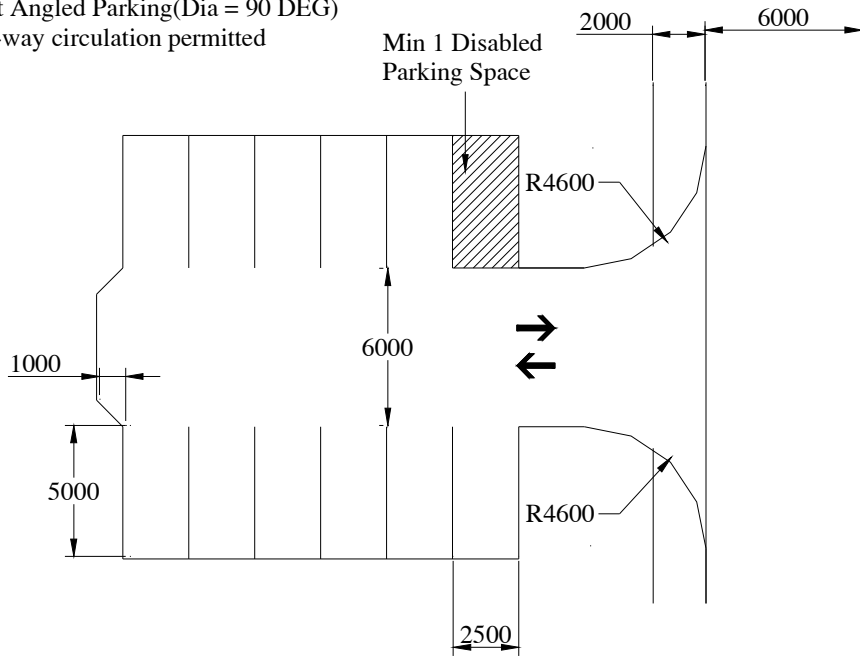

Footway crossings may replace Bellmouth for up to 10 spaces

Angled parking (0 < 90 DEG)  
One-way circulation only

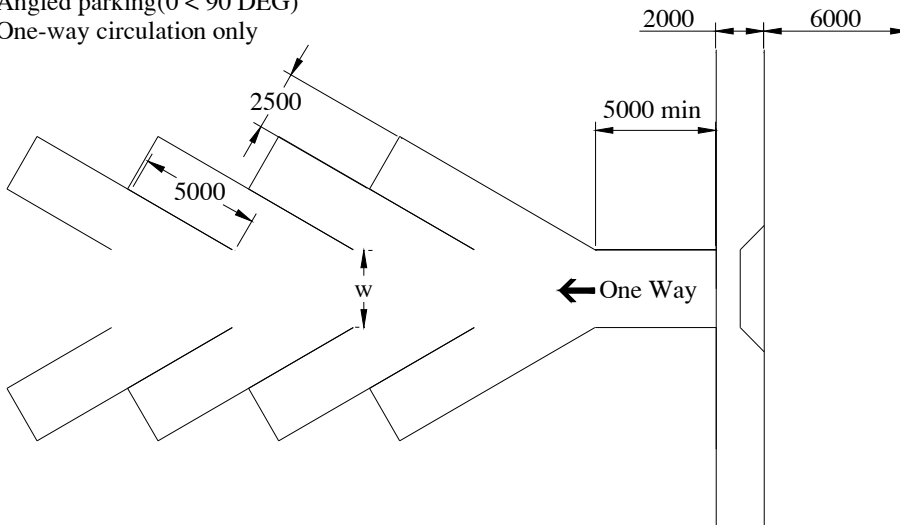





Angle of Parking	Aisle Width (w)
30	3.2m
45	3.4m
60	4.0m
75	4.7m
90	6.0m







Figure 26.1 - Off-Road Parking Areas

## Other Design Requirements

### 27. Statutory Undertakers' Services

- |  |      |   |
|--|------|---|
| Provision               | 27.1 | The provision of statutory or other services laid underground constitutes a basic element of development design. The Statutory Undertakers, who provide such services, must therefore be consulted during preparation of design briefs, so that their requirements can be co-ordinated in the design and a balance struck between their needs and other objectives.   |
| Routeing                | 27.2 | In the interests of both the Statutory Undertakers and their consumers all mains and services serving more than one proprietor should be located in land which is readily accessible. It has been recognised that these criteria are best met by public roads and, as well as making provision for pedestrian and vehicular movement; it is therefore a function of most roads to provide routes for underground services.  |
| Routeing in Home Zones  | 27.3 | Areas to allow routeing of Undertakers' services must form an integral part of any Home Zone design. Early consultation with all the Statutory Undertakers will be crucial in the delivery of a successful Home Zone development.   |
| Location               | 27.4 | Sewers will normally be placed under the carriageway and early consultation should be made with Scottish Water regarding that Authority's provision, in accordance with the Sewerage (Scotland) Act 1968, of surface water sewers, for the drainage of roofs and paved areas within the curtilage of premises, and the foul water drainage system. All services other than sewers, and occasionally water mains shall be grouped in "service corridors" located within the limits of footways, verges, adoptable footpaths (Section 3.3) with a minimum of service connections across the carriageway.  |
| Service Corridors     | 27.5 | The width of a service corridor will depend on the number and type of premises served. Normally, all domestic services (gas, electricity, lighting, water and telephones) will be accommodated in a 2 metres wide reservation and Figure 27.1 shown typical positions, the minimum clearance between each service being to the satisfaction of the Statutory Undertakers. This diagram is, however, only a guide and does not absolve the designer from negotiating with each of the Statutory Undertakers in turn at the earliest possible stage since, in any development, the depth, clearance and relative position of each service will require to be decided by the Statutory Undertakers, and the method of laying cables and pipes left to their discretion. Special arrangements will require to be made where a footway is less than 2.0 metres wide, and local widening in excess of 2.0 metres may be necessary to accommodate access chambers or where roads have tight bends. |

Issue B

- Road Furniture and Lighting 
- 27.6 All road furniture should normally be located at the rear of footpaths/footways or recessed behind them and no furniture or structures should obstruct any road junction sight line. Conversely, no services other than road lighting cables should be located within 0.5 metre of the rear of the footway to allow for lighting columns and joint pillars or other road furniture. Detailed guidance regarding the provision of road lighting is contained in Section 32.
- Maintenance Access 
- 27.7 Ready access must be available at all times to all parts of service routes for maintenance and in cases of emergency. Lorry access will be needed to some places such as manholes, electricity sub-stations, Telecommunication junction boxes and gas governor house installations; and the Statutory Undertakers' requirements for such facilities should be ascertained at an early stage. They should be positioned so as to minimise disruptions to vehicle and pedestrian access when service maintenance is being carried out, whilst ensuring that access to services will not itself be obstructed by parked vehicles. Special consideration in this respect will be necessary where services run beneath or adjacent to single lane carriageways and parking bays.
- Fire Hydrants 
- 27.8 The position of all hydrants should be agreed with the Fire master and Scottish Water and be clear of the possibility of vehicles being parked on top of them.
- Carriageway Crossings 
- 27.9 Where service corridors or branch connections cross the carriageway, cabled services should be individually ducted at increased depths in accordance with the requirements of the Statutory Undertakers as directed by the Local Roads Authority's Representative.
- Manholes 
- 27.10 Manholes in the road should be positioned outwith the vehicle wheel tracks as far as possible. In culs-de-sac care should be taken in positioning the manhole, to ensure that access is not blocked when the manhole is open.
- Landscaping 
- 27.11 Any landscaping of service corridors must conform with Section 34 and be such that each service runs at a constant depth. It is essential that any adjacent trees are located so that their roots will not damage services underground or be damaged themselves during the maintenance of such services.
- Location Plans 
- 27.12 The proposed location of all services within road boundaries, including those required under The New Roads and Street Works Act 1991, should be indicated on plans submitted to the Local Roads Authority's Representative for Construction Consent as detailed in paragraph 4.3(b).

Issue B

Existing  
Services 

27.13 The developer is responsible for contacting the Statutory Undertakers regarding the position of, and connection to, any existing underground plant. In all cases the Local Roads Authority's Representative must be contacted to determine the road opening permit requirements before any excavation is undertaken in a public road.

Installation of  
Services 

27.14 Any person wishing to install apparatus in the public road shall apply for permission under Section 109 of the New Roads and Streetworks Act or be acting as a Statutory Undertaker in full accordance with the terms of the New Roads and Streetworks Act.

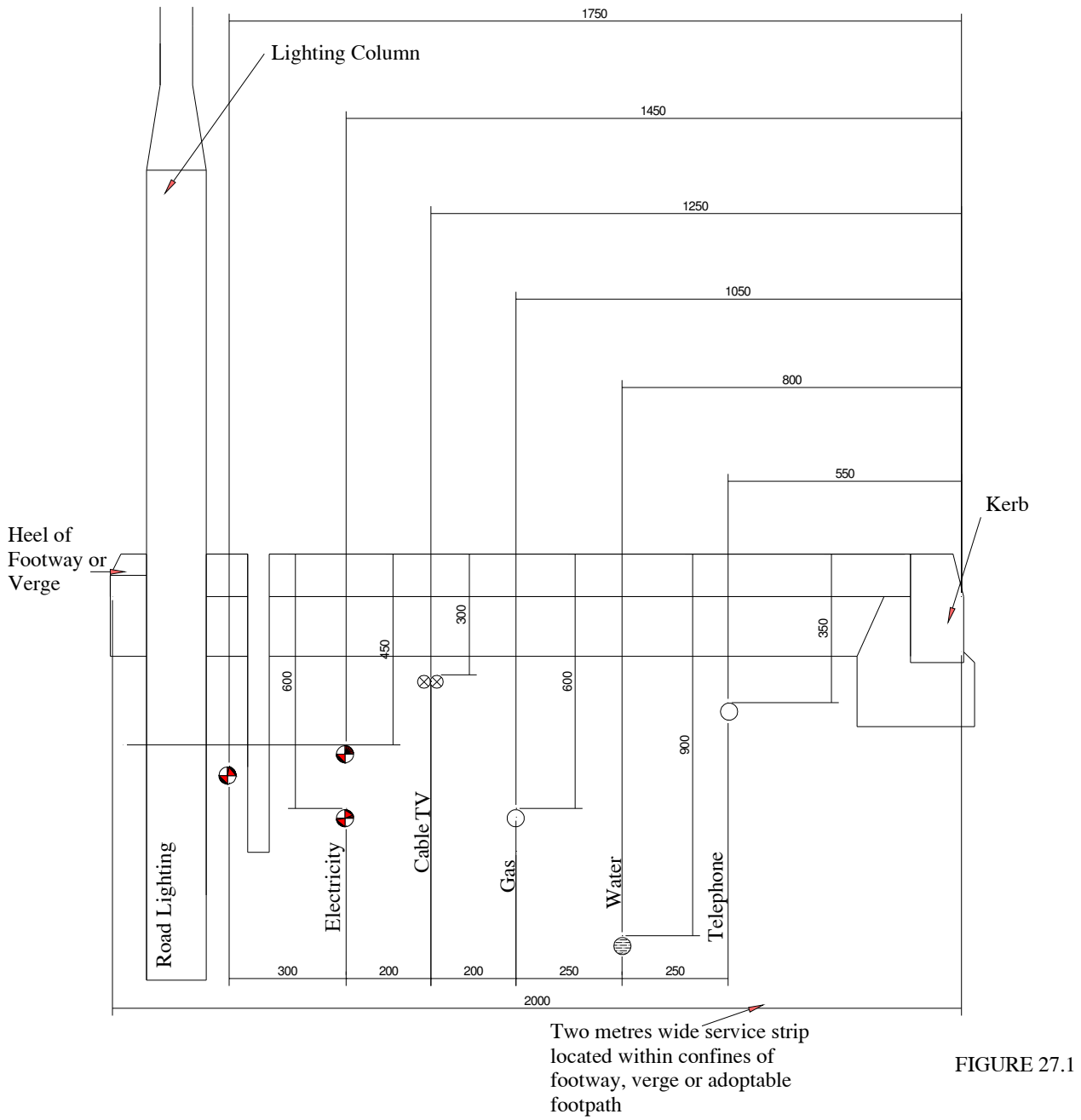











FIGURE 27.1

## FIGURE 27.1 - LOCATION OF SERVICE MAINS

## 28. Additional Design Considerations

- Headroom  28.1 **The minimum headroom for any structure other than a footbridge must be in accordance with TD 27/05 when spanning a PRIMARY or DISTRICT DISTRIBUTOR ROAD and 5.1 metres for all other roads, including those through pends.** The minimum headroom for footbridges must be in accordance with TD 27/05 in all cases. Appendages to buildings (i.e. sunblinds, projecting signs, etc) should be fixed at least 2.4 metres above adjacent footways, footpaths or verges.
- Disabled Persons  28.2 It is a statutory requirement to have regard to the needs of disabled people in designing any building to which the public have access. This will include the provision of suitable access routes for wheelchairs and the marking out of parking bays for use by disabled drivers (Section 26.8) close to pedestrian entrances.
- Bus Services  28.3 In planning major new developments, the need to provide or augment local bus services will have an effect on road layout, widths, corner radii and pedestrian access arrangements. For phased development, consideration should be given to encouraging access by bus services at an early stage, for the convenience of the first residents (see also Section 3.2).
- Bus Stops  28.4 Bus routes, in order to be practical, must be reasonably fast and direct and connect the centroids of the residential, business and shopping areas which they serve. Services will generally be based on DISTRICT and LOCAL DISTRIBUTOR ROADS although to achieve the desired penetration it may be necessary to use access roads (suitably widened if required). Ideally bus penetration should be such that no house or workplace is more than 400 metres from the nearest bus stop where these are spaced at two or three per kilometre.
- Bus stops will require to be provided with raised height kerbs, to improve the accessibility to the buses. The standard layout for raised height kerbs is shown on Figure 28.2.
- Where bus shelters are to be provided, these should be sited so as not to obstruct vehicle sight lines or footways. Bus shelters must be of a style approved by the Local Roads Authority's Representative.
- Road Widths for Bus Routes  28.5 The minimum carriageway width for two-way operation of buses in new development should be 6.0 metres and bus bays may be required.
- Traffic Management  28.6 The layout of a development may be influenced by existing or proposed traffic management measures and the Local Roads Authority's Representative should be consulted about these at an early stage. Where traffic management measures are to be introduced to facilitate a particular development, the developer will be required to fund these measures, including any costs associated with the promotion of the required traffic orders.

- Fire Fighting**  28.7 The width of roads and reinforced emergency vehicle paths and their proximity to buildings is detailed in part E of the Building Standards (Scotland) Regulations. This document specifies a minimum width of 3.7 metres adjacent to low rise dwellings to facilitate the use of pumping appliances (this width is increased to 4.5 metres to permit the use of heavy rescue and fire fighting equipment where buildings are 9 metres or more in height). It should be noted that the 4 metres width is appropriate for access but not operation of the fire tender in this case.
- Refuse Collection**  28.8 The Buildings Standards (Scotland) Regulations permit a maximum carry distance for dustbins of up to 46 metres. However, British Standard Code of Practice, BS 5906, suggests a maximum carry distance of 25 metres and it is recommended that this standard be adopted as far as possible. Where communal refuse storage accommodation is provided, the Regulations require that this be located no more than 15 metres from an access road suitable for use by refuse and recycling vehicles, and where such accommodation forms part of a chute system, or is used for the storage of bulk refuse containers, the access road should extend to the door of the accommodation. Developers should consult with Environmental Health on the proposed refuse collection arrangements for the development and take account of requirements for positioning of refuse and recycling containers for collection in designing pedestrian and vehicular routes within the site.
- Traffic Noise**  28.9 The Planning Authority will normally require new housing to be designed in accordance with Design Bulletin 26. Traffic noise from the following sources should be taken into account:
- (a) Existing roads
  - (b) New roads being constructed as part of the proposed development;
  - (c) Alterations to the road network to accommodate the proposed development;
- 28.10 Where existing roads are incorporated into a new housing development care should be taken to ensure that traffic noise levels do not exceed the specified level contained in the Noise Insulation (Scotland) Regulations 1975.
- 28.11 The developer should also take account of noise generated during the construction phase of the works and ensure that noise levels are maintained within acceptable limits. The Local Planning Authority should be consulted at any early stage to ensure that their requirements are met.
- Clearances**  28.12 A minimum 2.0 metres clearance is required at the ends of hammerheads etc where no footway is provided or adjacent to any walls or obstructions.
- 0.6 metres clearance should be provided to all street furniture



- 28.13 Developers are reminded of their responsibility to ensure that the design of road layout promotes safety. To that end the requirements of TD19/06 of DMRB should be taken into account in the design of any new development.

Safety barriers should be provided where required on single and dual carriageway roads with a speed limit in excess of 50mph in accordance with the requirements of TD 19/06. Safety Barriers will be required:-

- a) On embankments 6 metres or more in height
- b) On other embankments where there is a road, railway, water hazard or other feature (e.g. a subway entrance) at or near the foot of the slope
- c) On the outside only of curves less than 850 metres radius on embankments between 3 and 6 metres in height
- d) At obstructions including bridge piers or abutments, posts of large signs and sign gantry legs and trees
- e) At substantial obstructions such as retaining walls or steep sided (1 in 2 or steeper) rock face cuttings or earth bunds (1 in 1 or steeper) closer than 4.5 metres to the edge of the running carriageway
- f) At noise barriers or screens closer than 4.5 metres to the edge of the running carriageway

Safety barriers will also be required on dual carriageways that meet the following criteria:

- a) Motorways with central reserve up to 10 metres wide
- b) Dual two and three lane all purpose roads where the 24 hour AADT flow is expected to be greater than 30,000 vehicles in the year of opening
- c) At obstructions including bridge piers, sign gantry legs and trees
- d) Where there are lighting columns
- e) Where the difference in carriageway inner channel levels exceeds 1.0 metres and the slope across the central reserve exceeds 25%; the safety fence shall be sited at the top of the slope, but where the difference in carriageway inner channel levels exceeds 0.5 metres and the slope across the central reserve exceeds 15%, a case, including a forecast of costs and benefits, shall be submitted to the Local Roads Authority for approval
- f) Roads in urban areas with a 40 or 50mph speed limit without central lighting columns where the central reserve is less than 1.75m wide and adequate clearance between the face of the safety fence and the edge of the carriageway can be obtained.

For roads with a speed limit less than 50mph, guidance on this matter can be sought from the Local Roads Authority's Representative.

- 28.14 The Developer shall be required to install, at his own expense, the necessary traffic signs and associated road marking as required under the terms of the current version of the Traffic Signs Regulations and General Directions.

Further reference should be made to Section 33 of this guide.

- 28.15 Street name plates will be required at all road junctions. These items are essential to allow emergency services to navigate around new housing developments and are potentially life saving features.

As such the following criteria for the number of signs required at each style of junction is outlined below:

T – Junction

At both radii of the minor road for vehicles turning into the minor road.

Opposite the minor road junction for vehicles exiting the minor road. This is only to be provided if the main road is a Local Distributor or above.

T – Junction off a Cul-de-sac

As traffic will be predominately approaching the minor road from one direction then only one street name plate is required on the minor road. This should be placed on the radii of the minor road facing the oncoming traffic.

Figure 28.1 shows a typical street name plate layout.

Figure 28.1: Street Name Plate Layout 

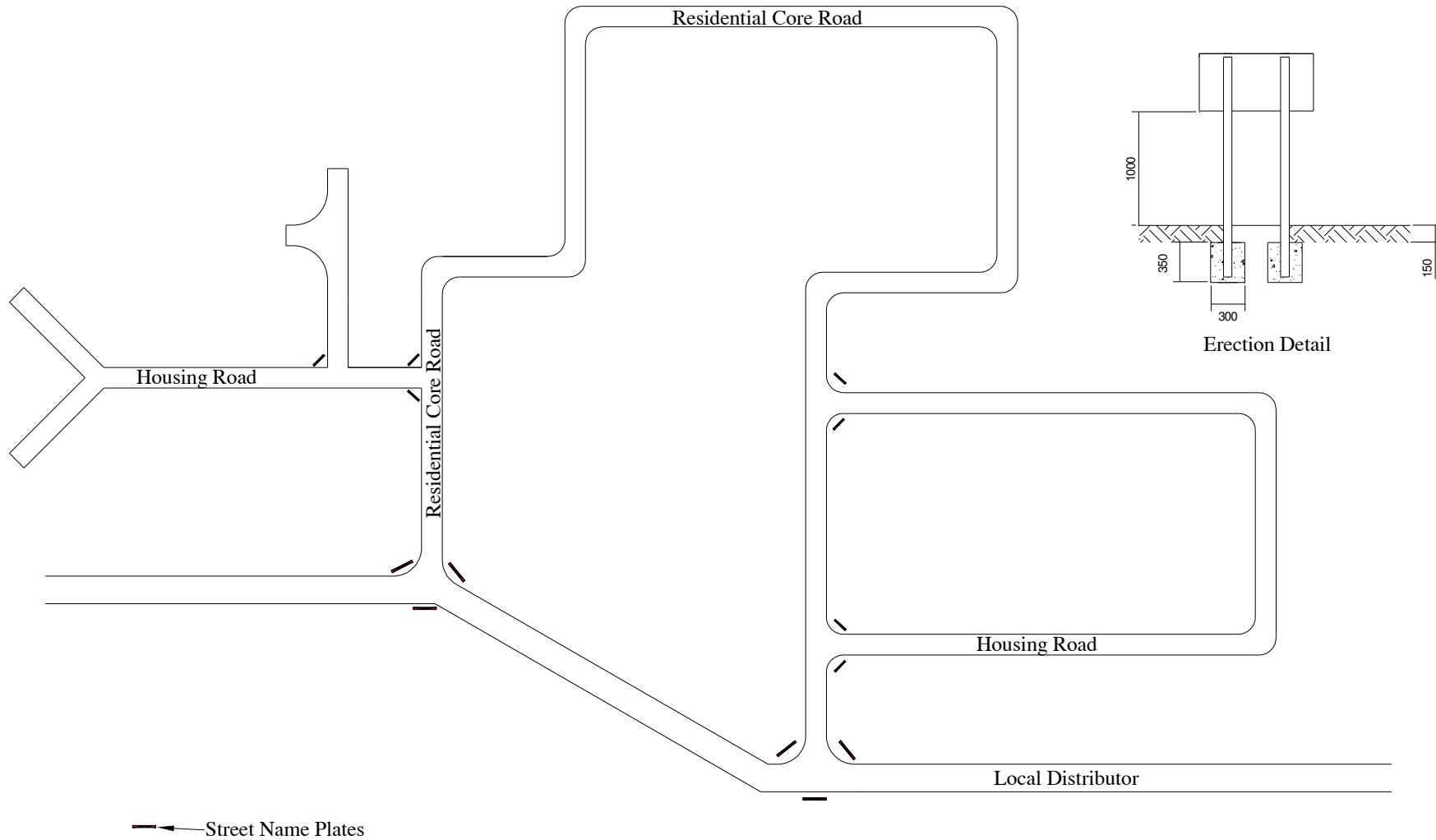
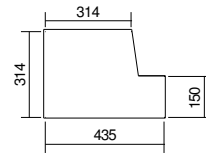
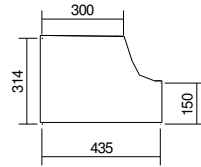
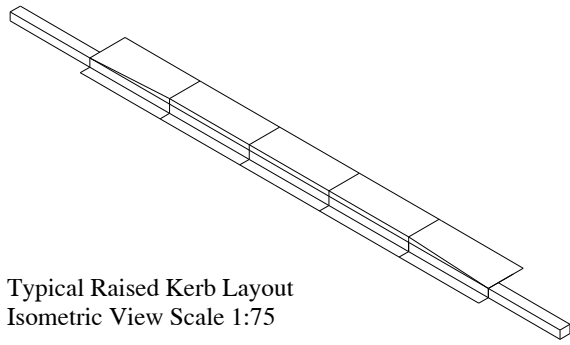
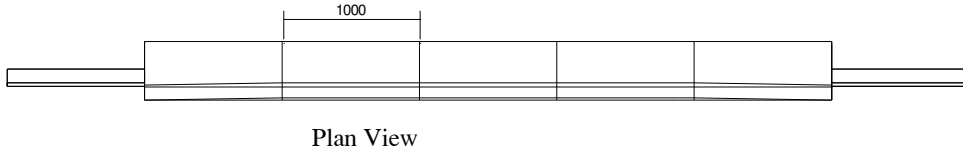
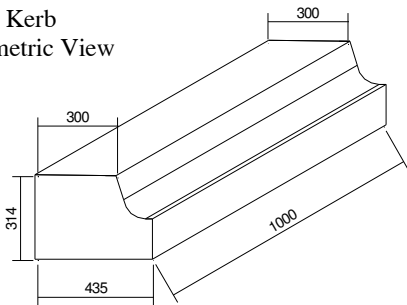

Figure 28.1 - Street Name Plate Layout

Typical Raised Kerb Layout  
(2 No. Transitions , 3 No. Full Height)  
Scale 1:50



Full Kerb  
Isometric View



Transition Kerb  
Isometric View

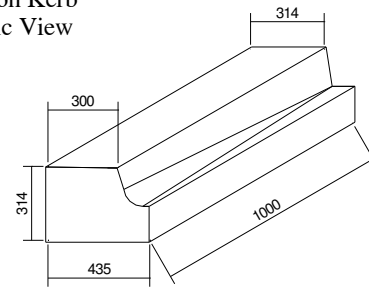

Footpath  
Construction



Typical Cross Section







Figure 28.2 - Bus Stop Kerb Detail

**Part 3 CONSTRUCTION DETAILS **

## 29. Geotechnical Considerations

- Introduction 
- Supporting Technical Documentation 
- California Bearing Ratio (CBR) 
- 29.1 The extent of the ground investigation requirements and the associated documentation will be dictated by the nature of the proposed development and the historical usage of the site.
- 29.2 All ground investigation reports shall comply with BS 5930:1999 Code of Practice for Site Investigation. The Factual Ground Investigation Report should include the following minimum information:
- a) Exploratory borehole/trial pit logs
  - b) Laboratory test data relevant to the proposed form of road construction
  - c) Location plan of the site at 1/2500 showing the proposed road network and borehole/trial pit locations
- The spacing of the boreholes/trial pits will depend upon the nature of the ground conditions and the proposed development. Sufficient locations should be chosen to ensure that the condition of the site can be fully identified.
- Full consideration should be given to the historic usage of the site and possible contamination. For further information reference should be made to BS 10175: Investigation of Potentially Contaminated Sites – Code of Practice: 2001.
- 29.3 The CBR value of the soil shall be determined by the laboratory CBR test in accordance with BS 1377: Part 4: 1990 and test data shall be incorporated in the Factual Ground Investigation Report.

### 30. Pavement Construction

- Specification  30.1 The specification for the construction of road pavements and associated structures is detailed in the specification section of this document. Clause numbers in the following text refer to that specification.
- Carriageway Construction  30.2 Carriageways for development roads up to Local Distributor or Industrial Access standard shall be constructed in accordance with Table 30.1 subject to the following qualifications:
- (a) No frost-susceptible material shall be permitted within 450mm of the final running surface. If the overall construction is less than 450mm, a certificate of non frost-susceptibility, for the sub-grade, is required;
  - (b) The formation CBR must not be less than 2%  
Submission of a site investigation report confirming the CBR value of the sub-grade, is required. For CBR values less than 2% see the current version of the Design Manual for Roads and Bridges.
- 30.3 All new roads other than those above shall have the carriageway designed as a flexible pavement in accordance with the following documents:  
TRRL Report LR 1132  
HD 26/06, and  
Volume 1 of the Manual of Contract Documents for Highway Works issued by Scottish Executive.
- Formation/Sub-Grade  30.4 Figure 30.1 gives depth of sub-base suitable for use when the sub-grade CBR is greater than 2%. Where the CBR is less than 15% a capping layer of selected fill or an increased depth of sub-base must be adopted. The diagram on Figure 30.1 should be used to determine allowable combinations of capping layer thickness and sub base thickness. It should be noted that the overall depth of carriageway construction must be at least 450mm. It may be the case that the minimum sub-base depth indicated in Figure 30.1 will have to be increased to achieve the 450mm depth.
- Sub-Grade Drainage  30.5 It is important to provide efficient permanent drainage of the sub-grade and any other permeable layer of road. The water table should be prevented from rising to within 0.6 metre of the formation level. This requirement is additional to those for surface water drainage detailed in Section 31.

Camber,  
Crossfall and  
Gradients 

- 30.6 Carriageways should be cambered with a fall of 2.5 per cent from the centreline to the channel except on curves where, to eliminate adverse camber, a crossfall of 2.5 per cent between channels should be provided. For roads surfaced with block paving a 2.5 per cent crossfall shall be provided throughout. At a junction, the carriageway of the minor road should be graded into the channel of the minor road.

Footways and footpaths shall be constructed with a crossfall of 2.5 per cent, and lay-bys shall be provided with a 2.5 per cent crossfall towards the road channel. Channel gradients shall not be flatter than 0.8 per cent (1 in 125). See Typical layout in Figure 30.5

Recycled  
Materials 

- 30.7 The use of recycled materials in carriageway and footway construction will be favourably considered in the following situations, at the discretion of the Local Roads Authority's Representative.
- (1) Recycled bituminous materials on the Base Layer of roads designed to carry up to 1.5 MSA.
  - (2) Recycled granular material in sub-base layers and capping layers if in accordance with the appropriate specifications for grading and frost susceptibility.
  - (3) Both recycled bituminous and granular materials will be allowed in footway, footpath and cycletrack construction.

Two Stage  
Construction 

- 30.8 Where, owing to the continued use of the road by construction traffic, it is necessary (in order to avoid damage to the Surface Course) to adopt a two - stage construction, a minimum Binder Course thickness of 55mm shall be provided. Consideration should be given to the condition of the temporary surface before the final course is laid. This applies particularly in large projects where the construction period may be long and the Surface Course not laid before the winter work period. Any settlement, which may occur in the Binder Course, should be taken up with Regulating Course before the laying of the Surface Course, and early reinstatement of openings or failed areas is essential. Before the Regulating Course or Surface Course is laid, the top surface of the Binder Course must be well cleaned and tack coat applied at the rate of 0.6 litres per square metre. If the developer wishes to omit the kerbs during the 1<sup>st</sup> stage construction an 'L' shaped kerb foundation (Figure 25.2) shall be used.

Tie in to Existing  
Carriageway 

- 30.9 It is important that special attention is paid to the area where new construction ties-in to the existing road network. This zone is prone to failure due to poor compaction and the ingress of water. In light of this all tie-ins should be constructed in accordance with the details shown in Figures 30.2 and 30.3.

Table 30.1 - Carriageway Construction 

Type	Sub Base	Base	Binder Course	Surface Course
Local Distributor Road (4 MSA)	See Figure 30.1(210mm Min) CI 803	140mm DBM CI 903	55mm DBM CI 906 Group Two CI 6.5	45mm HRA CI 911 or 910
Industrial Access Road (4 MSA)	See Figure 30.1 (210mm Min) CI 803	140mm DBM CI 903	55mm DBM CI 906 Group Two CI 6.5	45mm HRA CI 911 or 910
Core Road (2 MSA)	See Figure 30.1 (230mm Min) CI 803	120mm DBM CI 903	55mm DBM CI 912 Group Three CI 7.3	45mm HRA CI 911 or 910
Housing Road (0.7 MSA)	See Figure 30.1 (270mm Min) CI 803	80mm DBM CI 903	55mm DBM CI 912 Group Three CI 7.3	45mm HRA CI 911 or 910
Home Zone (0.5 MSA)	Consult Local Roads Authority's Representative	Consult Local Roads Authority's Representative	Consult Local Roads Authority's Representative	Consult Local Roads Authority's Representative

Concrete Block  
Carriageway  
Paving 

30.10 Block pavements may be acceptable for use in Home Zones.

Paving blocks shall be 100x200x80 in either red, buff, or charcoal, other colours to be specifically agreed with the Local Roads Authority's Representative. They will be laid to a Herringbone pattern with a stretcher course adjacent to kerbs, manholes and gullies. Cuttings, smaller than ¼ block will not be permitted. Gradients flatter than 1.25% are not recommended.

It is particularly important that the design of block pavements incorporates adequate provision for the drainage of unbound sub-base and sub-grade materials (Section 30.4) particularly where there are low longitudinal gradient. Where a 55mm Road base is incorporated to provide a temporary running surface adequate drainage of the bedding layer must be provided.

The method of construction and materials should be in accordance with BS EN1338:2003 Concrete Paving Blocks. Requirements and test methods and BS 7533-3:2005 Code of Practice for laying precast concrete paving blocks. Reference should also be made to "Concrete block paving: guide to the properties, design, construction, reinstatement and maintenance of concrete block pavements" published by Interpave.

Footway,  
Footpath and  
Cycletrack  
Construction 

30.11 Footways, footpaths and cycletracks shall be constructed in accordance with Table 30.2 and as detailed in Figures 30.5 & 25.1 respectively unless an alternative design is agreed with the Local Roads Authority's Representative.

It should be noted that under normal circumstances cycle tracks or shared pedestrian/cyclist facilities will only be permitted in Flexible Construction.

Flexible  
Construction 

30.12 Flexible footways, footpaths or cycletracks shall be constructed in accordance with Appendix 11/1-B of the Specification. It should be noted that Design Group A is not suitable for areas where services still have to be installed.

Concrete Slab  
Paving 

30.13 Concrete Slab paved footways or footpaths shall be constructed in accordance with Appendix 11/1-A of the Specification. It should be noted that Concrete Slab paving is not suitable for the construction of cycletracks or shared pedestrian /cyclist facilities.

Issue B

Small Element  
Slab Paving 

30.14 Concrete Small Element Slab paved footways and footpaths shall be constructed in accordance with Appendix 11/1 – A of the Specification. It should be noted that Concrete Small Element Slab paving is not suitable for the construction of cycletracks or shared pedestrian/cyclist facilities.

Block Paving 

30.15 Concrete Block paved footways or footpaths shall be constructed in accordance with Appendix 11/1 – D of the Specification. It should be noted that Concrete Block paving is not suitable for the construction of cycletracks or shared pedestrian/cyclist facilities.

Insitu Concrete  
Paving 

30.16 Insitu Concrete paving shall be constructed in accordance with Appendix 11/1 – C of the Specification. It should be noted that Insitu Concrete paving will only be acceptable in areas where there is a specific Planning requirement for the use of this material.

Granolithic  
Concrete  
Paving 

30.17 Granolithic Concrete paving shall be constructed in accordance with Appendix 11/1-E of the Specification. It should be noted that Granolithic Concrete paving will only be acceptable in areas where there is a specific Planning requirement for the use of this material.

Granite Slab  
Paving 

30.18 Granite Slab paving shall be constructed in accordance with Appendix 11/1-G of the Specification. It should be noted that Granite Slab paving will only be acceptable in areas where there is a specific Planning requirement for the use of this material.

Table 30.2 - Footway and Footpath Construction 

Type	Sub-Base	Binder Course	Surface Course
Flexible Construction	100mm granular sub-base Type 1 or Type 4 (cl 803 or 806)	40mm open or close graded Wearing Course Macadam (BS 4987, Part 1, Group three 7.1 or 7.3)	20mm dense or medium graded Surface Course Macadam (BS 4987 group three 7.5 or 7.6)  or 30mm HRA (BS 594, Table 6, Column 2, Schedule 1B)
Slabbed Construction	100mm granular sub-base Type 1 (cl 803)	25mm bed 6:1 sand/cement mixture	Hydraulically pressed concrete slabs 900 x 600 x 65mm and 600 x 600 x 65mm (cl 1104S)
Small Element Slabs	150mm granular sub-base type 1 (cl 803)	25mm bed medium course sand	Hydraulically pressed slabs 400 x 400 x 60mm
Block Paving (Pedestrian Traffic only)	100mm granular sub-base type 1 (cl 803)	50mm sharp sand bedding layer	100mm x 200mm x 60mm rectangular paving blocks (cl 1107)
In situ Concrete Construction*	75mm granular sub-base Type 1 (cl 803)		100mm in situ concrete slab
Granolithic Concrete Construction*	75mm granular sub-base Type 1 (cl 803)	80mm in situ concrete slab	20mm in situ granolithic concrete
Granite Sett Construction*	150mm granular sub-base Type 1 (cl 803)	50mm 1/4.5 cement/sand mortar	65mm Granite sett
Granite Slab Construction*	150mm granular sub-base Type 1 (cl 803)	50mm 1/3 cement/sand mortar	65mm Granite slab

\* These footway construction types are only suitable where required by specific planning requirements.

Kerbs and Edging 

30.19 All carriageways, footways, footpaths and cycletracks shall be provided with a precast concrete kerb or edging as detailed in Figures 25.1, 25.2 and 30.5. In Home Zones and where over the edge drainage is to be used edgings must be laid flush with the carriageway.

On conventional roads, with traditional drainage systems, kerbs shall be set 100mm above finished carriageway channel level, except at pedestrian and vehicular crossings where this dimension is reduced to 6mm and 20mm max respectively.

Edging at the back of footways should have an upstand of 50mm, whereas on footpaths and cycletracks it should be set flush with the walking/running surface.

Minor Accesses 

30.20 Where a vehicular access other than to individual dwellings is taken over a footway, a crossing, as detailed in Figure 25.3 should be provided with construction depths to the specification for a Housing Road carriageway.

Residential Accesses 

30.21 Vehicular access crossings of the footway to individual dwellings should comply with Figure 25.3 and be constructed to the footway specification for a Housing Road carriageway.

Pedestrian Crossings 

30.22 Figure 25.4 details the requirement for dropped kerbs where pedestrian routes cross the carriageway from adjacent footways (e.g. at T-junction and controlled crossings).

On all routes of Distributor Road classification, or higher, tactile paving must be incorporated into the design of the crossing points where the crossings is perpendicular to the main pedestrian flow, i.e. a pedestrian refuge.

Tactile Paving slabs should be installed in accordance with the recommendations in the Department for Transport's "Guidance on the use of tactile paving surfaces".

Pedestrian crossings in a road with an adjacent grass verge shall comply with Figure 25.3(b) except that the number of dropped kerbs should be two and they should be set a maximum of 6mm above the surface course.

Emergency Accesses 

30.23 Emergency accesses must be designed with sufficient bearing capacity to carry commercial vehicle loadings. Further advice can be obtained from the Local Roads Authority's Representative.

Construction to Housing Road standard will be acceptable for this purpose.

Figure 30.1: Capping and Sub-base **A**

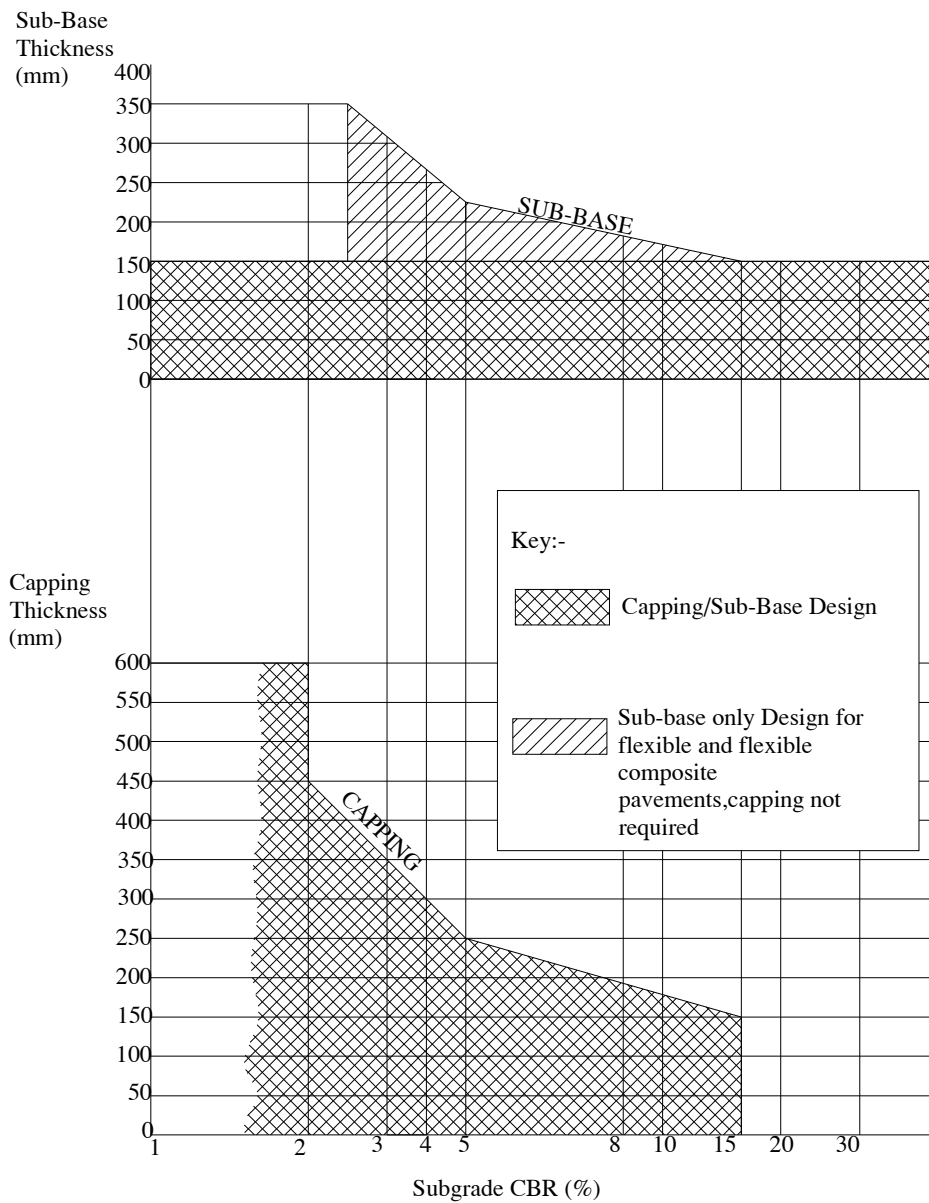

Capping and Sub-base Thickness Design

**Example 1 : CBR**

**3.5%**

Alternative Designs

- a. Sub-base 150mm  
on capping 330mm
- b. Sub-base 280mm  
No Capping

**Example 1 : CBR**

**8%**

Alternative Designs

- a. Sub-base 150mm  
on capping 210mm
- b. Sub-base 190mm  
No Capping

Figure 30.1 - Capping And Sub-Base

Figure 30.2: Longitudinal Tie in Detail 

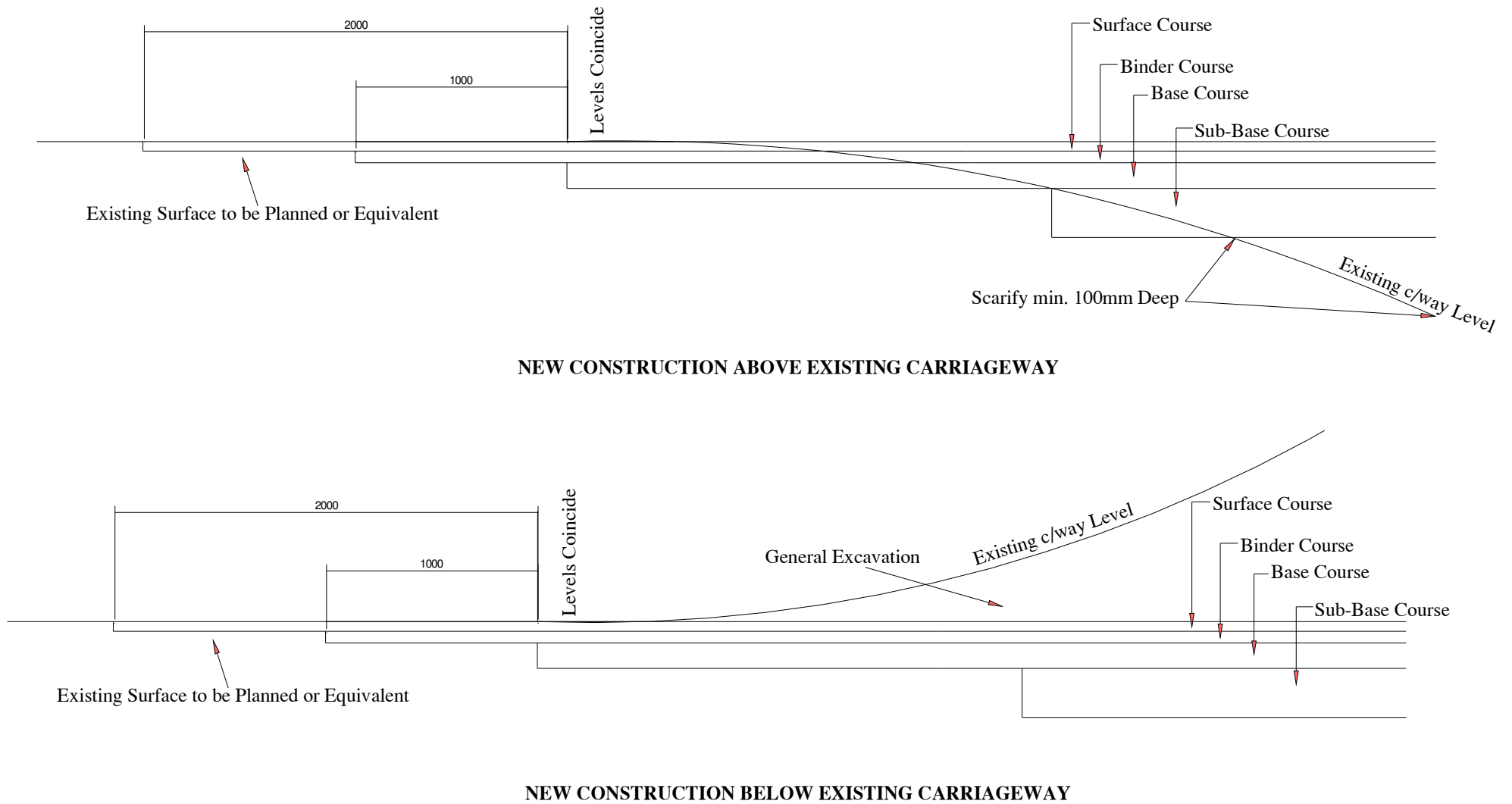



Figure 30.2 - Longitudinal Tie in Details

Figure 30.3: Carriageway Widening Tie in Detail 

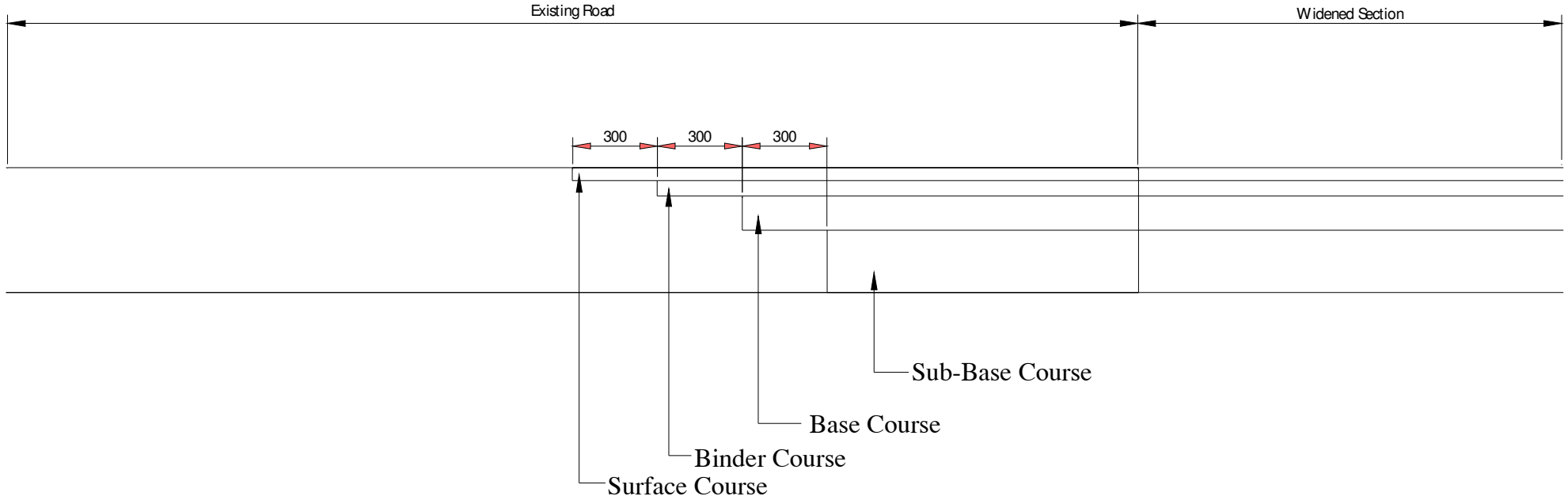

Figure 30.3 - Carrageway Widening - Tie in Detail

Figure 30.4: Buff Tactile Paving 

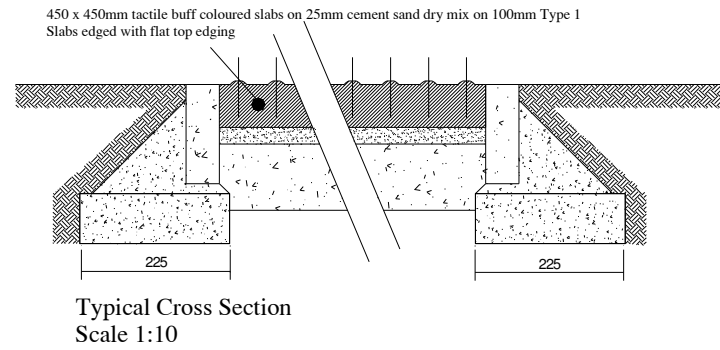
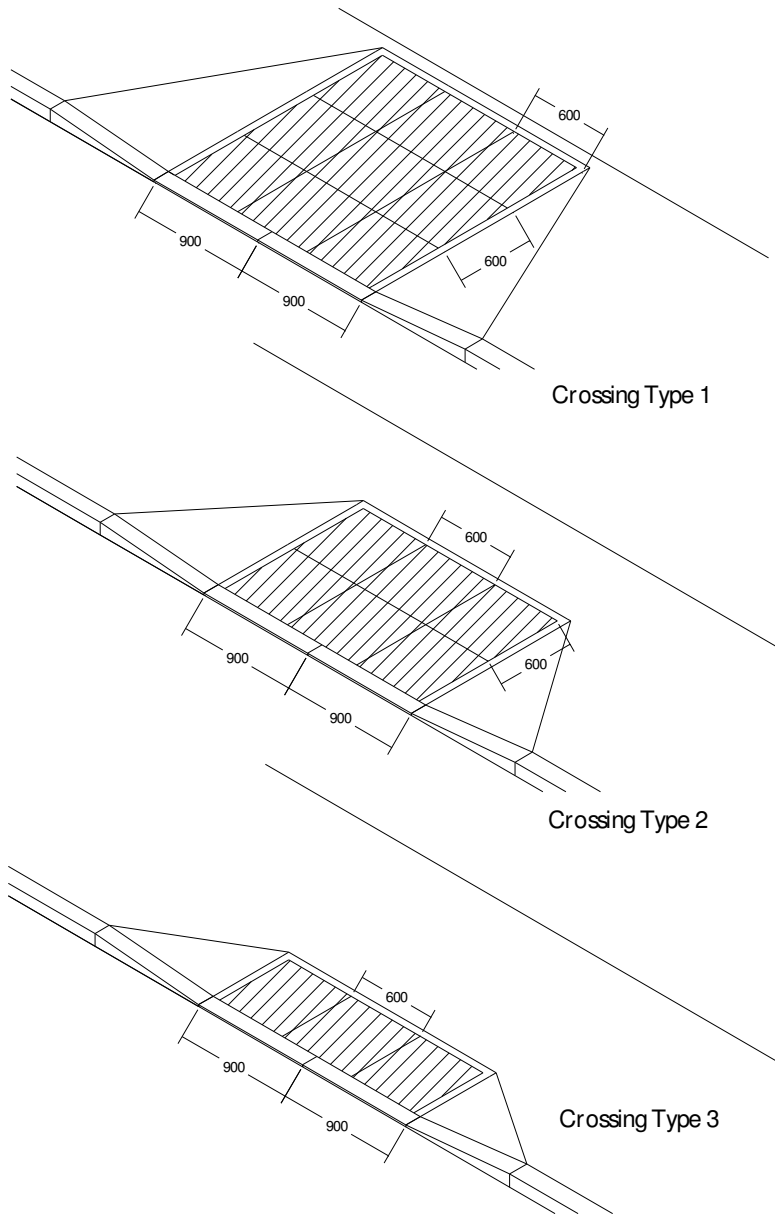

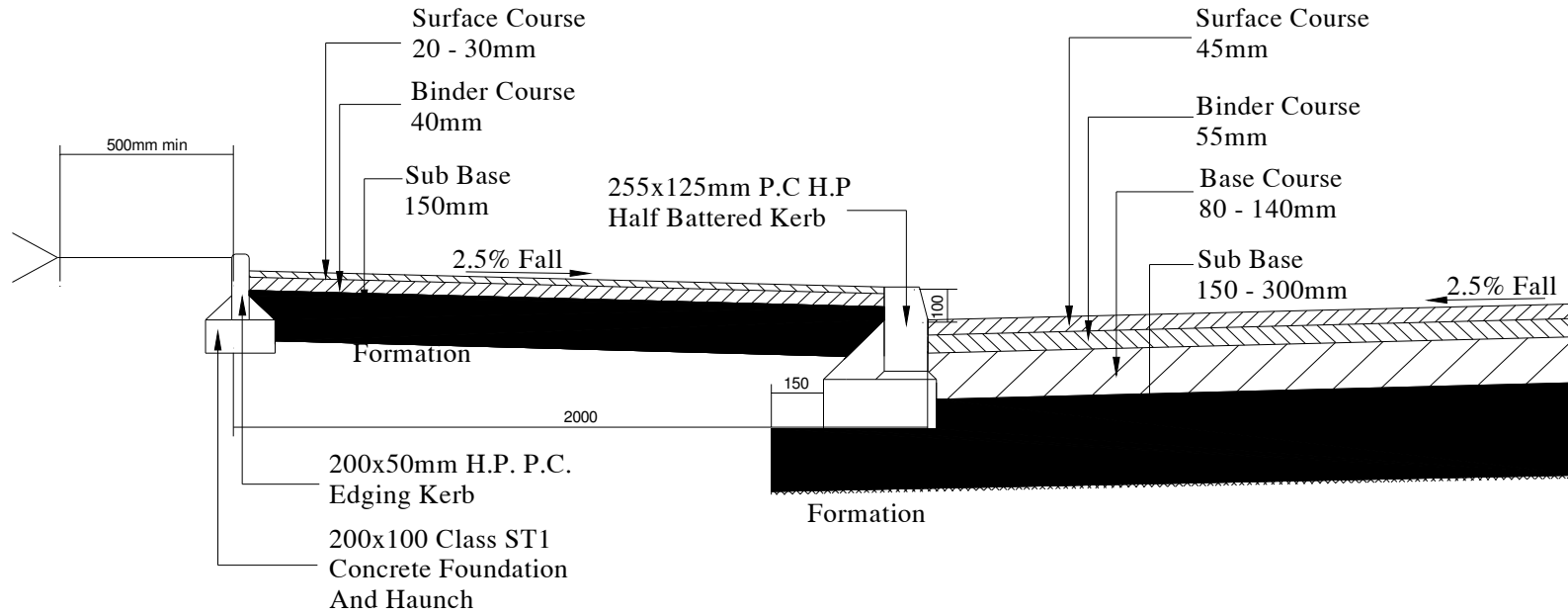



Figure 30.4 - Buff Tactile Paving

Figure 30.5: Typical Carriageway and Footway Construction 



**Figure 30.5 - Typical Carriageway and Footway Construction**

## 31. Road Drainage

Best  
Management  
Practices 

31.1 Any built up area will require to be drained to remove excess surface water. Traditionally this has been done using underground pipe systems designed for the quantity of runoff, to prevent flooding locally. As the pipe system removed runoff from the area more quickly than natural flow it has the potential to cause problems in other areas of the catchment.

In recent years issues relating to water quality have become more important, due to pollutants being washed into watercourses and groundwater. Traditional drainage systems cannot easily deal with this particular issue and may actually add to the problems.

Continuing to drain built up areas in this manner is no longer a sustainable long-term option. Developers are therefore required to address surface water runoff by the incorporation of Sustainable Urban Drainage Systems (SUDS) into their overall design.

Sustainable  
Urban Drainage  
Systems 

31.2 Sustainable Urban Drainage Systems (SUDS) are made up of one or more structures built to manage surface water runoff. They are used in conjunction with good management of the site, to prevent pollution. There are four general methods of control:

1. Filter strips and swales
2. Filter drains and permeable surfaces
3. Infiltration devices
4. Basins and ponds.

These devices should be placed as close as possible to where the rainwater falls to provide attenuation for the runoff. The above measures also provide treatment for the surface water, in varying degrees, using the natural processes of sedimentation, filtration, adsorption, and biological degradation.

Further guidance on the design of SUDS can be obtained from Sustainable Urban Drainage Systems – Design Manual for Scotland and Northern Ireland, published by CIRIA (C521).

Drainage Impact  
Assessment 

31.3 For the majority of developments a Drainage Impact Assessment will be required. This document is usually included with the initial Planning Application, either Outline or Detailed. The DIA should be site specific and deal with all drainage aspects relating to the site and must demonstrate that the appropriate SUDS measures have been employed.

Further guidance on this matter can be found in “Drainage Impact Assessments – Guidance for Developers” published by the North East Scotland Flooding Advisory Group.

- Appropriate Level of Treatment **A**
- 31.4 Each site will have to be considered on an individual basis to determine the most effective combination of SUDS measures. However in general terms the runoff from every Residential Development should be subjected to one level of treatment before it is discharged.
- In general terms Non Residential sites will require 2 levels of treatment and Industrial sites will require 3 levels of treatment.
- Early contact with SEPA, Scottish Water and the Local Roads Authority is essential to ensure that these requirements are addressed early in the design stage.
- Road Drainage **A**
- 31.5 **To accommodate the requirements of SUDS road drainage will need to undergo at least one level of filtration before it is discharged into the public sewer or watercourse.**
- In addition the drainage system will be required to have a degree of storage to enable it to provide an acceptable level of attenuation in flood conditions**
- Further guidance on the design of SUDS can be obtained from Sustainable Urban Drainage Systems – Design Manual for Scotland and Northern Ireland, published by CIRIA (C521).
- Footpath /Cycletrack Drainage **A**
- 31.6 To remove gully-clearing difficulties, remote footpaths should be constructed with flush edging and adjacent land drainage provided as detailed in Figure 25.1. Only in exceptional circumstances, as agreed with the Local Roads Authority's Representative, should direct drainage into gullies be considered as an alternative.
- Design of Piped Road Drainage **A**
- 31.7 Piped Road drainage design should be in accordance with the current edition of the Design Manual for Roads and Bridges subject to the qualification that the minimum pipe diameter permitted will be 150mm. **Land drainage or other appropriate measures must be taken to prevent water flowing on to the road from adjacent properties.**

Gully Spacing 

31.8 Table 31.1 details the acceptable channel distance between gullies for a road comprising of carriageway and two 2 metre wide footways, or a road and two 3 metre wide footway/cycletracks for the 7.3m wide road. The gully spacing will be based on the criteria laid out in the Design Manual for Roads and Bridges, Volume 4, Section 2, Part 3, HA 102/00.

The following assumptions will be made in any gully spacing design:

Mannings 'n'	0.017
Storm Intensity	50mm/h
Flow Width	0.75m
Maintenance Factor	0.8 (0.7 for sag curves)
Min Grating Grade	T

The following special requirements will also apply:

- a) Terminal gullies must have an efficiency rating of at least 95%, to prevent excessive flow past the final grating.
- b) At sag points twin gullies are to be used. The efficiency of both these gullies must be at least 95%, to prevent excessive flow past the grating.

The spacing may require to be altered according to the road layout (e.g. at junctions) and special measures will be required where the grade is necessarily flatter than 0.8 per cent (sags, crests, etc). Advice on these matters should be sought from the Local Roads Authority's Representative who should be consulted at an early stage by any developer wishing to carry out a full drainage design. Irrespective of design spacing, a gully shall be positioned:

- a) Just upstream of the tangent point at road junctions;
- b) Short of the point where adverse camber is removed when applying super-elevation;
- c) At any local low point;
- d) At a maximum spacing of 50 metres;
- e) To allow a maximum drained area of 180 sq.m. per gully within irregularly shaped areas.

Lay-by  
Drainage 

31.9 Lay-bys shall be drained by means of gullies located along the road channel; it should not, therefore, be necessary to provide gullies at the rear of lay-bys/bus bays.

Irregular  
Areas 

31.10 For large, irregular shaped areas the empirically derived formula of one gully for each 180 square metres of catchment may be used. Additional gullies will be required where gradients are steeper than 5.5% (1 in 18) or flatter than 0.8% (1 in 125) and where surface water draining from adjacent areas may be anticipated.

Table 31.1 - Gully Spacing for Carriageways

Gradient		Flatter than 0.8% (1/125)*	0.8% 1/125	1.0% 1/100	1.25 1/80	1.66 1/60	2.5 1/40	5.0 1/20	5.55 1/18
Cross Section	C/W Width	Gully Spacing (metres)							
2.5% (1/40) Camber	5.5m	15	18	19.5	21.5	24.5	29	37.5	39
	6.0m	14	17	18.5	20.5	23	27.5	35.5	37
	7.3m	11	13	14	15.5	17.5	20.5	27	28
2.5% (1/40) Crossfall	5.5m	7.5	9	10	11	12	14	19	20
	6.0m	7	8.5	9	10	12	14	18	19
	7.3m	5.5	6.5	7	7.5	8.5	10	13	14

\* Gradient flatter than 0.8% applicable to crests and sags only.

## Gullies

- 31.11 Road gullies must be constructed in accordance with Clause 508 of the specification and fitted with external traps as shown on Figure 31.1. Gully pots should be either 450mm inside diameter (I.D.) precast concrete or 450/510mm I.D. insitu concrete with plastic former. Gully gratings and frames must be Class D400 complying with BS EN124 and be of a size compatible with the gully pot. Gully frame is to be 100mm deep. Gully grating is to be set 6mm below the road surface.

Note: Bars of gratings to be at right angles to kerb line, and where applicable hinge side to be facing oncoming traffic.

## Connections

- 31.12 Where gullies are to be connected to a surface water drain it shall be by 150mm diameter jointed fire-clay or plastic pipes, which will be surrounded with 150mm of Class ST1 concrete where the cover to the earthworks outline is less than 0.9 metres.

Connections should be constructed in accordance with Clause 508 of the Specification.

Where Land drains are to be connected to the surface water drain it must be via a silt trap.

Down Pipes 

31.13 In redevelopment areas existing down pipes, which may have previously discharged over the footway or through a channel, must be connected either directly into a gully pot or its connection with 100mm jointed pvc or fire-clay pipes. Permission will be required from Scottish Water and SEPA for this form of surface water treatment.

Chambers 

31.14 Chambers should be constructed as detailed in Volume 3 of the Manual of Contract Documents for Highway Works and must be to the satisfaction of the adopting authority. All covers shall incorporate a permanent non-rock feature either triangular point suspension of machined faces.

All covers should be hinged and have a minimum clear square opening of 600mm. All manhole covers shall open such that an operative will have an unobscured view of the oncoming traffic when entering and leaving the manhole.

Where circumstances do not allow normal compaction to be carried out between manholes etc. Class ST1 concrete will be required to be placed as directed by the Local Roads Authority's Representative.

Pipework 

31.15 All pipework for road drainage must be designed in accordance with Volume 4, Section 2, Part 5, HA 40/01 of the Design Manual for Roads and Bridges and constructed in accordance with the Manual of Contract Documents for Highway Works.

Outfall  
Connection 

31.16 The connection of road drainage systems to the public sewer network must be undertaken only with the authority of Scottish Water (Section 27). When connecting to an existing watercourse, approval must be sought from the Scottish Environmental Protection Agency. Permission under Section 109 of the New Roads and Street Works Act will be required where apparatus is to be installed in the public road.

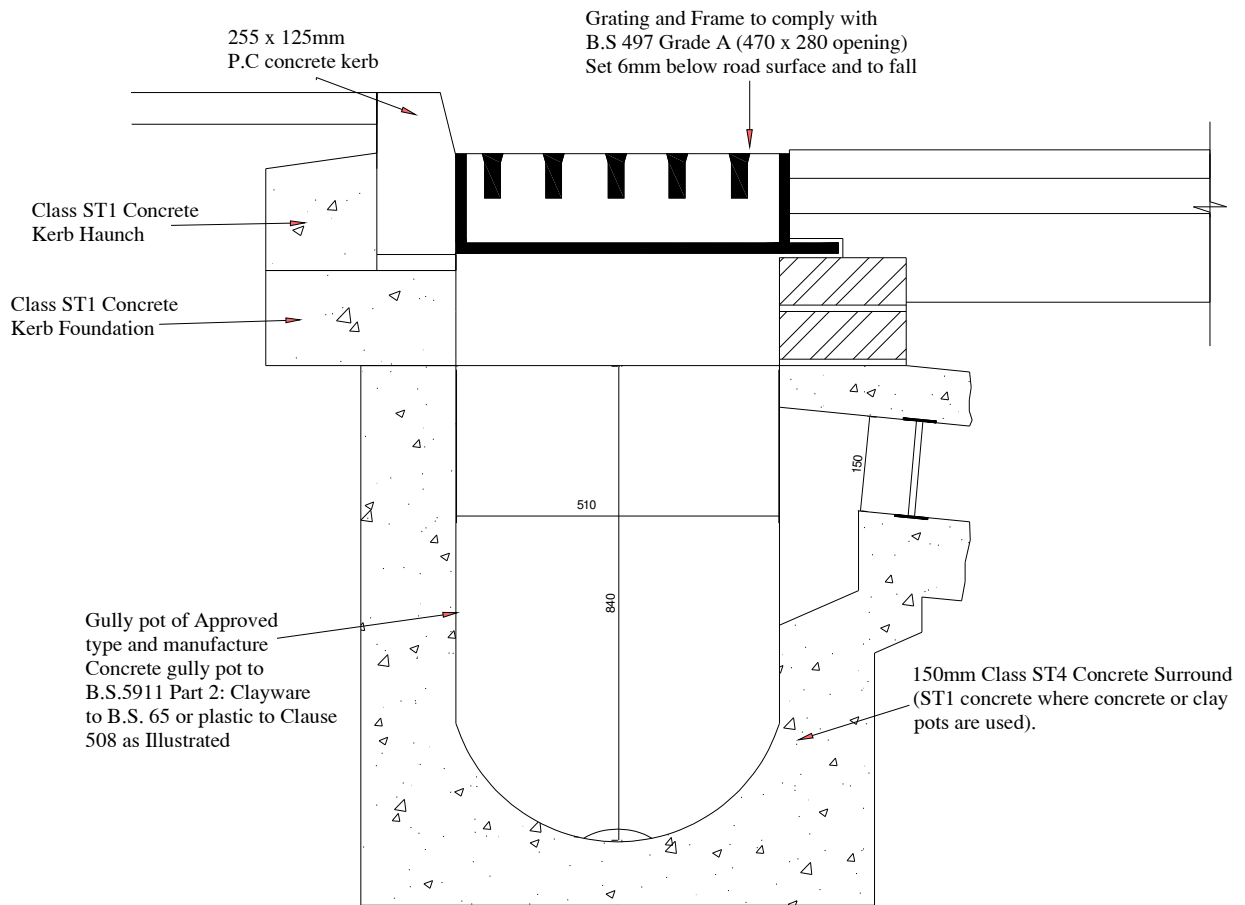







Figure 31.1 - Typical Road Gully





## 32. Road Lighting

- Application for Consent  32.1 It is important that Developers consult the Local Roads Authority's Representative at an early stage, as adjustments to the lighting design may be necessary to meet Construction Consent requirements. In addition the Local Roads Authority's Representative will give guidance on the type of lantern and lamp that may be appropriate for the development.
- Information to be Supplied  32.2 Applications for Construction Consent should be accompanied by **three paper copies of detailed drawings showing the following:**
- Location and type of lighting columns and lanterns, wall mounted units (if applicable), feeder pillars, underground cables (including size and type and sections to be ducted) and road crossing ducts.
- Further guidance on this matter can be found in Section 4 of this guide.
- Inspections  32.3 The Developer is reminded of his obligation to give the Local Roads Authority's Representative a minimum of 48 hours notice of the following operations:
- Setting out of road lighting plant and positions, backfilling of trenches and painting of lighting columns.
- Specification  32.4 The specification for the provision and installation of road lighting shall be the current version of the Specification for Highway Works, with amendments and additions as detailed in Appendix 13 of the Specification.
- Design  32.5 Lighting shall be designed to comply with the requirements of BS 5489 Parts 1 to 9. Lighting on carriageways with footways having an overall width of up to and including 9.10 metres shall comply with Category 2 of Part 3. For Primary or District Distributor Roads the lighting shall comply with Category 1 of Part 3.
- Where a speed limit of 60kph (40mph) or higher is to apply to a road the Developer should seek guidance from The Local Roads Authority's Representative on the standard of lighting required. The road lighting design should be agreed with the Local Roads Authority's Representative prior to application being made.
- For combined footpaths/cycletracks lighting shall be provided to comply with the requirements of BS 5489:Part 9, Section 3, Clause 14 and the lighting levels shall be as specified in Table 6 of BS 5489.

In addition to the requirements of BS 5489 the following lantern restrictions will apply:

Residential Road	Half cut off
Distributor Road and above	Full cut off

**Lighting design calculations showing the levels achieved from the proposed layout and equipment must accompany the application.**

- |  |       |   |
|--|-------|---|
| Location of Apparatus   | 32.6  | While the approximate location of all lighting apparatus should be indicated on the drawings, the exact position must be determined on site and approved by the Local Roads Authority's Representative. Lighting columns should normally be located at the rear of the footway or where there is a grass verge adjacent to the carriageway, at the heel of this verge. Underground lighting cables should be correspondingly located within 0.3 metre of the rear of the footway or verge (Figure 27.1) and the Developer must ensure that no other service is allowed to encroach within this area. The routes of any surface cables must be agreed with the Local Roads Authority's Representative prior to their installation. |
| Decorative Equipment  | 32.7  | Decorative lighting equipment usually has significant maintenance cost implications and for this reason it is limited to high amenity and conservation areas. Consultation with the Planning Authority may be necessary and the approval of the Local Roads Authority's Representative must be obtained.  |
| Column Location       | 32.8  | In the absence of a footway the minimum clearances from the edge of the carriageway to the lighting column shall be a minimum of 1.0 metre as detailed in BS 5489 Part 1, Clause 9.1.   |
| Road Opening Permit   | 32.9  | The Developer must obtain the necessary permission under Section 109 of the New Roads and Streetworks Act where apparatus is to be installed in the public road.  |
| Existing Services     | 32.10 | The Developer is responsible for contacting the Statutory Undertakers regarding the position of any existing underground plant.   |

Maintenance 

32.11 Only roads which have been constructed in accordance with a Construction Consent approval will be considered for public lighting which would be adopted for maintenance by the Local Roads Authority.

The maintenance of all lighting shall be the responsibility of the developer until such time as the road and lighting are formally adopted by the Local Roads Authority. The Local Roads Authority's Representative will require written confirmation on **Form CC8** (obtainable at the Transportation and Infrastructure offices or the Aberdeenshire Council Web Site) that an agreement has been reached with a suitable lighting contractor to ensure that the lighting is maintained to the required standard. This may be a service which the Local Roads Authority can supply, on a fully rechargeable basis.

Electricity Supply 

32.12 The Developer will require to make application to the relevant electricity supplier for a connection from an unmetered supply to the street lighting feeder pillar or column where required.

32.13 Where the supply is to be taken from existing lighting installations belonging to the Local Roads Authority, the final connection must be made by the Local Roads Authority's contractor on a rechargeable basis.

Electricity Consumption 

32.14 The Developer will require to make arrangements with the relevant power supplier in relation to payment for electricity consumed by the street lighting until such time as the road and lighting are formally adopted by the Local Roads Authority.

The Local Roads Authority's Representative will require written confirmation that such an agreement is in place.

Bond 

32.15 In the event of a developer failing to provide operational street lighting adjacent to occupied housing, he will be given 28 days notice to make such provision. Failure to comply with this requirement within the period of notice will result in the Local Roads Authority arranging for procedures to be initiated to call in the Bond to fund the installation of the required street lighting apparatus.

Similarly, failure to rectify a fault resulting in malfunction of the street lights, **within a period of 5 days** will cause the Local Roads Authority to effect a repair with the costs being invoiced to the Developer.

### 33. Traffic Signs and Road Markings

#### Responsibility of the Developer

33.1 The Developer will be required to provide appropriate traffic signs and road markings as directed by the Local Roads Authority's Representative. The full cost of this provision will be borne by the Developer.

#### Design and Sitting of Traffic Signs

33.2 All traffic signs will be designed in accordance with the current version of the Traffic Signs Regulations and General Directions, the Traffic Signs Manual, and BS EN12899-1:2001 – Fixed Vertical Road Traffic Signs.

Traffic sign poles should be designed to accommodate a wind pressure of 15 millibars (156 kg/sq.m.)

The materials used for the construction of the sign faces and the poles will meet the relevant standards as set out in Appendix 12 of the Specification.

#### Road Markings

33.3 Junction markings will be required at most junctions. Where any road joins a Distributor, or higher, classified road junction marking and signage shown on Figure 18.4 will be required.

If the junction is with a Core Road the junction markings shown in Figure 18.5 will be required. In certain circumstances this requirement may be relaxed at the discretion of the Local Roads Authority's Representative.

In general no junction markings will be required when both roads are Housing Roads classification or less.

These marking will be in accordance the current version of the Traffic Signs Regulations and General Directions.

The road markings material will comply with BS EN 1436 and the requirements of Appendix 12 of the Specification.

Street Name  
Plates **A**

- 33.4 Street name plates will be required at all road junctions. These items are essential to allow emergency services to navigate around new housing developments and are potentially life saving features.

As such the following criteria for the number of signs required at each style of junction is outlined below:

T – Junction

At both radii of the minor road for vehicles turning into the minor road

Opposite the minor road junction for vehicles exiting the minor road. This is only to be provided if the main road is a Local Distributor or above.

T – Junction off a Cul-de-sac

As traffic will be predominately approaching the minor road from one direction then only one street name plate is required on the minor road. This should be placed on the radii of the minor road facing the oncoming traffic.







Figure 28.1 shows a typical street name plate layout and erection details.

Alterations to  
Existing  
Signage **A**

- 33.5 In some cases as a result of the development alterations will be required to existing road markings and signs on the public road. Any such requirements will be notified to the Developer by the Local Roads Authority's Representative at the Consent approval stage.

The Developer will be responsible for carrying out the required alterations and will be responsible for meeting the full cost of any such alterations.

## 34. Road Landscaping

- Specification  34.1 The specification for road landscaping is detailed in Appendices 6/8 and 6/9 of the Specification.
- Design  34.2 Any landscaping proposed for areas within the road boundaries should be designed to minimise future maintenance requirements as determined by the Local Roads Authority's Representative.
- Soft Verge  34.3 Soft verges shall be grassed in accordance with Appendix 6/8 of the specification unless an alternative form of surfacing is authorised by the Local Roads Authority's Representative, in consultation with the Statutory Undertakers where appropriate. There must be a permanent and continuous demarcation of the boundary between the verge and adjoining private property (e.g. by a fence, wall or concrete edge kerbing).
- Topsoil  34.4 Topsoil shall be spread to a uniform thickness on all areas to be seeded as specified in Appendix 6/8 of the specification. Prior to soiling, the top 200mm of existing ground should be broken up to facilitate drainage.
- Grass Seed  34.5 Unless otherwise agreed by the Local Roads Authority's Representative, grass seed should comprise the mixture listed in Appendix 6/8 to the Specification. The Developer will be responsible for resowing, in the following season, any area where the seeding is not successful.
- Hard Verges  34.6 The form of any hard landscaping should be agreed with the Local Roads Authority's Representative at an early stage in the design process. Where hard verges are provided on distributor roads, they shall be surfaced with pedestrian deterrent paving, e.g. cobbles set in concrete, or upstand setts.
- Scottish Water may require "grasscrete" or similar to be provided in specific locations.

## **35. Contact Names and Addresses**

### **Banff / Buchan and Buchan**

Local Roads Manager – Alistair J MacKinnon

Location – Cape House  
21 Seafield Street  
Banff  
AB45 1ED

Telephone Number – 01261 813414 (Direct Dial)  
01261 813200 (Switchboard)

### **Formartine and Garioch**

Local Roads Manager – Ian Rendall

Location – Gordon House  
Blackhall Road  
Inverurie  
AB51 3WA

Telephone Number – 01467 628086 (Direct Dial)  
01467 620981 (Switchboard)

### **Kincardine / Mearns and Marr**

Local Roads Manager – Mark Skilling

Location - Carlton House  
Arduthie Road  
Stonehaven  
AB39 2DQ

Telephone Number – 01569 768534 (Direct Dial)  
01569 768455 (Switchboard)

## 36. Glossary

**“Approaches”** - in relation to a bridge or tunnel, includes the facings of any embankment or cutting adjacent to the bridge or tunnel;

**“Building”** – includes any erection, however and with whatever material, it is constructed and any part of a building;

**“Carriageway”** – shall be construed in accordance with section 11 of the Roads (Scotland) Act 1984;

**“Cattle Grid”** – has the meaning given by section 41(6) of the Roads (Scotland) Act 1984;

**“Classified Road”** – shall be construed in accordance with section 11 of the Roads (Scotland) Act 1984;

**“Common”** – has the same meaning as in the Acquisition of Land (Authorisation Procedure) (Scotland) Act 1947;

**“Cycle Track”** – shall be construed in accordance with sub-section (2) of the Roads (Scotland) Act 1984 below;

**“Days”** – means clear days;

**“Enactment”** – includes an enactment in this act or in a local or Private Act and a provision of an order, a scheme, regulations or any other instrument made under or confirmed by a public general local or private act;

**“Footpath”** – shall be construed in accordance with subsections (2) and (3)(a) and (b), and “footway” in accordance with subsection (2) in the Roads (Scotland) Act 1984, below;

**“Frontager”** – in relation to a road or proposed road, means the owner of any land fronting or abutting it;

**“Improvement”** – in relation to a road, means the doing of anything for the benefit of road users, or any class of road users, beyond that which is essential to placing the road in a proper state of repair, and includes the improvement of the amenity-

- (a) of the road; and
- (b) of land abutting on, or adjacent to, the road;

**“Local Authority”** – means a regional or islands council;

**“Local Roads Authority”** – has the meaning given by paragraph (a) of the definition of “roads authority” in this subsection;

**“Maintenance”** - includes Repair; and  
Watering to allay dust but, without prejudice to subsection (1) of section 25 of the Local Government and Planning (Scotland) Act 1982 (restriction 1982 c. 43.of powers of local authorities as regards street cleansing), not such cleansing as an islands or district council are required by subsections (1) and (3) of that section to undertake;

**“Navigation Authority”** – means persons authorised by any enactment to work, maintain, conserve, improve or control any canal or other inland navigation, navigable river, estuary, harbour or dock;

**“Notice”** – means notice in writing;

**“Obstruction”** – includes obstruction of view;

**“Occupier”** – means the person in occupation or having the charge, management or control of land, either on his own account or as the agent of another person

**“Open Space”** – has the same meaning as in the Acquisition of Land (Authorisation Procedure) (Scotland) Act 1947 c. 42. 1947;

**“Operator”** - in relation to a telecommunications code system, has the same meaning as in paragraph 1 of the Schedule 4 to the Telecommunication Act 1984;

Issue B

**“Owner”** –

(a) In relation to land means, subject to paragraph (b) below, the person for the time being entitled to receive, or who would, if the same were let, be entitled to receive, the rents of the land, and includes a trustee, factor, tutor or curator, and in the case of public or municipal property applies to the persons to whom the management thereof is entrusted; and

(b) In relation to special roads (whether existing or proposed) includes any person who under the Lands Clauses Acts would be entitled to sell and convey the land to promoters of an undertaking and also includes a lessee under a lease the unexpired portion of which exceeds three years;

**“Pedal Cycle”** - means a cycle whose motive power is provided solely by the legs of its rider or riders or which complies with the requirements specified in Regulations 4 of the Electrically Assisted Pedal Cycles S.I. 1983/1168. Regulations 1983;

**“Private Road”** – means any road other than a public road;

**“Proposed Road”** - means (without prejudice to the definition in this subsection of “proposed public road”) a new road in course of construction, or proposed to be constructed, by or on behalf of any person;

**“Proposed Public Road”** – means either -

A new road in course of construction or proposed to be constructed, by or on behalf of a roads authority; or

An existing road which is prospective public road within the meaning of the Public Utilities Street Works Act 1950;

**“Public Road”** means a road which a Roads Authority have a duty to maintain:

**“Railway Undertakers”** - means persons authorised by any enactment to carry on a railway undertaking;

**“Road”** – means, subject to subsection (3) below, any way (other than waterway) over which there is a public right of passage (by whatever means) and includes the road’s verge, and any bridge (whether permanent or temporary) over which, or tunnel through which, the road passes; and a any reference to a road includes a part thereof;

**“Roads Authority”** –

a) In relation to a road or proposed road other than any such as is mentioned in paragraph (b) of this definition, the regional or islands council within whose area the road is (such council being in the Roads (Scotland) Act 1984 referred to as a “local roads authority”); and

(b) In relation to a Trunk Road (whether existing or in course of construction) or, without prejudice to section 4 of the Roads (Scotland) Act 1984, to a special road provided by him under section 7(5) (or to be provided by him under section 7(5)(a) or (b) or to any other road constructed (or to be constructed) by him under section 19(1) of the Roads (Scotland) Act 1984, the Secretary of State; and references to “they” in relation to a roads authority shall be taken to relate also to the Secretary of State;

**“Special Road Authority”** – has the meaning given in section 7(4) of the Roads (Scotland) Act 1984;

**“Special Road”** – means a road provided or to be provided in accordance with a scheme under section 7 of the Roads (Scotland) Act 1984;

**“Statutory Undertakers”** – has the same meaning as in section 275 of the Town and Country Planning (Scotland) Act 1972 except that it includes the post office and, except in sections 133 and 140(4) of the Roads (Scotland) Act 1984, the operator of any telecommunications code system;

**“Swing Bridge”** – includes any opening bridge operated by mechanical means

**“Telecommunication Apparatus”** - “the telecommunications code” and “telecommunications code system” have the same meanings as paragraph 1 of Schedule 4 to the Telecommunication Act 1984

**“Tidal Waters”** – has the same meaning as in section 35(1) of the Rivers (Prevention of Pollution) (Scotland) Act 1951

**“Traffic”** – includes pedestrians and animals

**“Traffic Sign”** – has the same meaning as in section 64(1) of the Roads Traffic Regulations Act 1984;

Issue B

**“Trunk Road”** – means a road which is a trunk road by virtue of section 5 of the Roads (Scotland) Act 1984 or of an order or direction under that section or section 198(2) of the Town and Country Planning (Scotland) Act 1972;

**“Use”** – in relation to a road, includes crossing;

**“Vehicle”** – means a vehicle of any description and includes a machine or implement of any kind drawn or propelled along roads (whether or not by mechanical power);

**“Water Authority”** – shall be construed in accordance with section 3 of the Water (Scotland) Act 1980; and 1980 c. 45.

**“Works”** – as regards any road, includes-

- a) Making an alteration to it;
- b) Breaking up or opening it;
- c) Constructing or laying anything under it;
- d) Building anything into it; and
- e) Carrying out any other operations of a like nature;

and cognate expressions shall be construed accordingly.

## 37. Bibliography

<b>Title</b>	<b>Publisher</b>
Circular 6/2001 – 20 Mph Speed Limits	Scottish Executive
Construction (Design and Management) Regulations 2007	Health and Safety Executive
Designing For Deliveries	Freight Transport Association
DMRB – Design Manual For Roads and Bridges	Scottish Executive
Inclusive Mobility	Department for Transport
Noise Insulation Scotland Regulations	Scottish Executive
Road Hump (Scotland) Regulations 1998	Scottish Executive
Road Humps and Traffic Calming Scotland Amendment Regulations	Scottish Executive
Roads (Scotland) Act 1984	Scottish Executive
Security for Private Roads Works Regulations 1985	Scottish Executive
Technical Standards Scotland Building Regulations	Scottish Executive
The Home Zones (Scotland) (No.2) Regulations	Scottish Executive
Traffic Signs Regulations and General Standards	Scottish Executive
Transport (Scotland) Act 2001	Scottish Executive

## 38. Safety Audit Stages

### Stage 1 (Preliminary Design – Order Publication Report Stage)

<u>Contents</u>	<u>Items</u>
A1: General	Departures From Standards Cross Sections Cross-sectional Variation Drainage Climatic Conditions Landscaping Public Utilities/Services Apparatus Laybys Access Emergency Vehicles Future Widening Staging of Contracts Adjacent Development
A2: Local Alignment	Visibility New/Existing Road Interface Vertical Alignment
A3: Junctions	Layout Visibility
A4: Non motor vehicle provision	Adjacent Land Pedestrians/Cyclists Equestrians
A5: Signs and Lighting	Signs Lighting Poles/Columns
A6: Construction and Operation	Buildability Operation Network Management

## Stage 2 (Completion of Detailed Design – Works Commitment Stage)

1. The Audit Team should satisfy itself that all issues raised at Stage 1 have been resolved. Items may require further consideration where significant design changes have occurred.
2. If a Scheme has not been subject to a Stage 1 Audit, the items listed in lists A1 to A6 should be considered together with the items listed below

<u>Contents</u>	<u>Items</u>
B1: General	Departures of Standards Drainage Climatic Conditions Landscaping Public Utilities/Services Apparatus Laybys Access Skid Resistance Agriculture Safety Fences Adjacent Developments and Roads
B2: Local Alignment	Visibility New/Existing Road Interface
B3: Junctions	Layout Visibility Signing Lighting Road Markings T, X, Y-Junctions All Roundabouts Mini Roundabouts Traffic Signals
B4: Non Motor Vehicle Provision	Adjacent Land Pedestrians Cyclists Equestrians
B5: Signs and Lighting	ADS and Local Traffic Signs Variable Message Signs Other Traffic Signs Lighting Road Markings Poles and Columns
B6: Construction and Operation	Buildability Operation Network Management

### Stage 3 (Substantial Completion) – Prior to opening Road

1. The Audit Team should Consider whether the design has been properly translated into the scheme as constructed and that no inherent safety defect has been incorporated into the works.
2. Particular attention should be paid to design changes which have occurred during construction

#### Contents

C1: General

#### Items

Departures from Standards  
Drainage  
Climatic Conditions  
Landscaping  
Public Utilities/Services Apparatus  
Access  
Skid Resistance  
Safety Fences  
Adjacent Development  
Bridge Parapets

C2: Local Alignment

Visibility  
New/Existing Road Interface

C3: Junctions

Visibility  
Road Markings  
Roundabouts  
Traffic Signals  
T and Y Junctions

C4: No motor vehicle provision

Adjacent Land  
Pedestrians  
Cyclists  
Equestrians





C5: Roads Signs, Carriageway Markings and Lighting

Signs  
Variable Message Signs  
Lighting  
Carriageway Markings

C6: Operation

Maintenance  
Network Management

## 39. Accessible Design and Access Audits

- Policy Statement** 
- 39.1 The Policy of Aberdeenshire Council, Transportation and Infrastructure, Roads Service is to comply with the requirements of the Disability Discrimination Act 1995 and in particular with the requirements of Part III of the Act to remove or alter physical barriers that prevent disabled people gaining access to service, or to provide the service in an alternative way where reasonable.
- Design Standards** 
- 39.2 “Inclusive Mobility – A Guide to Best Practice on Access to Pedestrian and Transport Infrastructure” (Published by the Department for Transport in 2002 ) has been adopted by Aberdeenshire Council, Transportation and Infrastructure, Roads as the guidance document for design to meet the requirements of the Disability Discrimination Act, Part III.
- The design standards and principles included in the document shall be the Desirable Standards for all designs and shall be those against which Access Audits shall be carried out.
- Departures from Desirable Standards** 
- 39.3 All reductions in the Desirable Standards shall be considered as a **Departure from Standard** and each Departure shall be assessed to determine if it is “reasonable”.
- The process of assessment shall be documented to demonstrate that it has taken place between the Designer, Checker and Access Auditor.
- The documentation in respect of Departures shall be submitted as part of the Roads Construction Consent application.
- Access Audits** 
- 39.4 The approach adopted for the assessment of designs to determine their compliance with desirable design standards is similar to the established procedure for Safety Auditing.
- The approximately equivalent stages are as detailed below :-
- Stage 1 Safety Audit - Preliminary Access Audit
  - Stage 2 Safety Audit - Design Access Audit
  - Designer’s Risk Assessment - Access Statement
  - Stage 3 Safety Audit - Post-Construction Access Audit

Access Auditor 

39.5 Access Audits shall be carried out by a trained Access Auditor independent of the design team for the project.  
Access Auditors shall be registered with:-  
The National Register of Access Consultants , 70 South Lambeth Road, London, SW8 1RL, (www.nrac.org.uk)  
Tel: 020 7735 7845, Fax: 020 7840 5811  
either as Access Auditors or Access Consultants.

Where more than one stage of Access Auditing is required the same Auditor shall, where possible, carry out all of the stages.

Access Audit Procedure 

39.6 A Design Access Audit shall be carried out for all projects and an Access Statement submitted as detailed below.

For complex schemes it may be advantageous to carry out a Preliminary Access Audit in order to identify any features requiring particular attention at an early stage in the design process.

Post-construction Access Audits shall not generally be required unless recommended by the Access Auditor in the Design Access Audit Report.

The Designer shall produce an Audit Brief, as detailed below, for each required Access Audit stage.

For each audit the Access Auditor shall consider whether any additional items require to be considered and add these to the checklist to form a scheme-specific list.

Access Audit Brief 

39.7 The Audit Brief shall include the following where applicable:-

Previous Access Audit Report(s) and Summary Sheet(s).

Previous Safety Audit Report(s).

Details of revisions to the project subsequent to the last Audit Report.

A description of the project including background information.

A list of all Departures from Desirable Standards including reasons for the Departure and any mitigating features included in the design. The list should be referenced to a plan showing the locations of the Departures.

Existing and proposed Traffic and Pedestrian Counts where applicable. Where pedestrian or cycle routes, with a higher than average usage by disabled people, form part of a project, or pass through a project, details of usage should be supplied.

Plans at suitable scales showing (where applicable):-

- (i) Location Plan including details of adjacent property use;
- (ii) General Arrangement Drawing ;
- (iii) Gradients (longitudinal and cross-falls);
- (iv) Steps and Ramps ( Including long-sections, cross-sections, details of steps, platforms, materials and finishes);
- (v) Surfacing and paving materials (including finishes and colours);
- (vi) Kerbing and edging (including tap rails and cycle lane dividers);
- (vii) Street Furniture ( including materials and colours);
- (viii) Signage (including pole sizes, mounting heights and pole colours and details of lettering for pedestrian signs);
- (ix) Road Markings;
- (x) Hand Rails (including heights, details of construction, materials and finishes);
- (xi) Pedestrian and Vehicular Barriers;
- (xii) Pedestrian Crossing Points (including for controlled crossings details of push-buttons and signage);
- (xiii) Bus Stops and Shelters (including details of real-time displays, timetables and seating);
- (xiv) Lighting (including type of lighting and light levels);
- (xv) Any other scheme-specific features the Project Manager considers relevant.

A sample Audit Brief and Schedule are shown in Section 39.13, pages 170-172 for information purposes only.

Audit Report 

- 39.8 The Auditor shall produce an Audit Report identifying any aspects of the design requiring to be addressed by the design team and including recommendations. The report shall also include recommendations for further stages of Access Auditing where the Auditor considers this desirable.

An Audit Report Summary Sheet (See Section 39.14) shall be included identifying the principal elements of the project.

Designer's Response 

- 39.9 Where features of the design have been identified in the Audit Report as unacceptable the Designer shall respond to the Auditor's report either by amending the design to eliminate the problem identified, introducing additional mitigating features, or by producing a case for retaining the feature which concerned the Auditor. This response shall be submitted in writing to the Auditor who will either sign off the Audit with no further action required or return further comment.

Issue B

Dispute  
Resolution 

39.10 In the event that agreement cannot be reached between the Designer and the Auditor, to allow the Auditor to sign off the Audit, the disputed element of the Audit shall be identified in the Roads Construction Consent submission.

Project Access  
Statement 

39.11 The following records :-

- (xvi) Audit Brief(s) ;
- (xvii) Audit Report(s) ;
- (xviii) Audit Report Summary Sheet(s) in the form as in Section 39.14 ;
- (xix) Designer's responses ;
- (xx) Dispute Resolutions.

shall form the Access Statement for the project.

Maintenance  
and Repair 

39.12 Where there are elements of the design that have specific operational or maintenance requirements in order to comply with the requirements of the Disability Discrimination Act these shall be identified in the Roads Construction Consent submission.

**ACCESS AUDIT BRIEF FOR *Project Title***

<b><u>AUDIT</u></b>			
Audit Stage:			
Preliminary: <input style="width: 40px; height: 25px;" type="checkbox"/>	Design: <input style="width: 40px; height: 25px;" type="checkbox"/>	Post-Construction: <input style="width: 40px; height: 25px;" type="checkbox"/>	
Submission Date for Report :			
Audit to be charged to Job No:			
Issued By:.....	Accepted By:.....		
Date:.....	Date:.....		
<b><u>PROJECT</u></b>			
Project Title:			
Location:			
Client:			
Client's Address:			
Job Code:		File Reference:	
<b><u>CONTACTS</u></b>			
Client's Representative:		Telephone:	
Project Manager:		Telephone:	
Principal Designers:		Telephone:	
<b><u>DESCRIPTION OF PROJECT</u></b>			
(Description shall include purpose of project as detailed in Design Brief/Commission Basis Statement and any relevant background information)			

<b><u>DEPARTURES FROM DESIRABLE STANDARDS</u></b>				
(Include reasons for Departure and mitigating features included in the design) A reference drawing showing the location of all Departures is appended to this Document.				
Departure Reference Drawing No:				
<b><u>REF. NO.</u></b>	<b><u>DESCRIPTION</u></b>	<b><u>PROPOSED MITIGATION</u></b>		
<b><u>ACCESS AUDIT HISTORY</u></b> (Complete as Applicable)				
Preliminary	Date:		Auditor :	
Design	Date:		Auditor :	
Post-Construction	Date:		Auditor :	
<b><u>SUMMARY OF REVISIONS TO DESIGN SUBSEQUENT TO LAST AUDIT</u></b>				
(Where revisions relate to specific items within previous Audit Report include reference to the relevant section of the Report)				

<b><u>INFORMATION SUPPLIED</u></b>	
<b>The following information is supplied as part of this brief :-</b>	<b>(X)</b>
Previous Access Audit Reports	<input type="checkbox"/>
Safety Audit Reports	<input type="checkbox"/>
Location Plan and details of adjacent property use	<input type="checkbox"/>
General Arrangement Drawing including relevant plan dimensions and showing the location of all of the details identified below	<input type="checkbox"/>
<b><u>Details</u></b>	
Surface Gradients - longitudinal and cross-falls	<input type="checkbox"/>
Steps, Ramps and Platforms – Long-sections, cross-sections, dimensions, tolerances, materials, finishes, colours	<input type="checkbox"/>
Hand Rails – Dimensions, materials, finishes, colours	<input type="checkbox"/>
Pedestrian and Vehicular Barriers – Dimensions, materials, finishes, colours	<input type="checkbox"/>
Surfacing and Paving – Dimensions, Tolerances, materials, finishes, colours	<input type="checkbox"/>
Kerbing, Edging, Tap Rails and Cycle Lane Dividers - Dimensions, tolerances, materials, finishes, colours	<input type="checkbox"/>
Street Furniture - Dimensions, materials, finishes, colours	<input type="checkbox"/>
Signage – pole sizes, mounting heights, materials, colours, letter fonts and sizes	<input type="checkbox"/>
Road Markings Vehicular and Pedestrian	<input type="checkbox"/>
Pedestrian Crossing Points – Detail of construction and associated features and signage	<input type="checkbox"/>
Bus Stops and Shelters – Detail of construction and associated features and signage	<input type="checkbox"/>
Lighting – type and location and light levels	<input type="checkbox"/>
Other Scheme - Specific Features (List Below)	<input type="checkbox"/>

<b>AUDIT REPORT SUMMARY SHEET FOR :-</b> <i>(Project Title)</i>			
<b>Audit :</b> <i>(Delete as Applicable)</i>	<b>Preliminary</b>	<b>Design</b>	<b>Post-Construction</b>
<b>Designer :</b> <i>(Name, Position, Company)</i>			
<b>Access Auditor :</b> <i>(Name, Position, Company)</i>			
<b>Element of Project</b>		<b>Designer</b>	<b>Access Auditor</b>
	<b>Signed</b>		
	<b>Date</b>		
	<b>Signed</b>		
	<b>Date</b>		
	<b>Signed</b>		
	<b>Date</b>		
	<b>Signed</b>		
	<b>Date</b>		

## APPENDIX A

### List of Consultees

#### Sustainable Urban Drainage Systems

Scottish Water  
Kingshill House  
Arnhall Business Park  
Westhill  
Aberdeenshire  
AB32 6UF

Scottish Environmental Protection Agency  
Greyhope House  
Greyhope Road  
Torry  
Aberdeen

Aberdeenshire Council, Planning and Environmental Services  
Appropriate Area Office.

#### Traffic Calming Measures

The Firemaster  
Grampian Fire Brigade  
19 North Anderson Drive  
Aberdeen  
AB15 6DW

Chief Ambulance Officer  
Scottish Ambulance Service  
Ashgrove Road West  
Aberdeen  
AB16 5EG

The Chief Constable  
Grampian Police  
Operational Support Division  
Nelson Street  
Aberdeen  
AB24 5EQ

## **APPENDIX B**

### **Design and Check Certificates**

**DESIGN CERTIFICATE **

*DEVELOPER:* .....

*PROJECT:* .....

**SCHEDULE OF THE DESIGN ELEMENTS**

Design Element Reference Number	Description of Design Element	Location of Design Element	Designer	Checker
1	Conceptual Layout			
2	Horizontal Alignment			
3	Vertical Alignment			
4	Traffic Calming			
5	Visibility Requirements			
6	Carriageway Construction			
7	Carriageway Drainage			
8	SUD System			
9	Street Lighting Layout			
10	Street Lighting Apparatus			
11	Bridges/Culverts			
12	Retaining walls and other Structures			

**Note: This list is not exhaustive and may require additional elements to be added**

Dated this ..... day of .....

Signature ..... in the capacity of .....

Name (print) .....

Duly authorised to sign and acknowledge the contents of Design Certificate for and on behalf of:-

Postal Address .  
 .....  
 .....

Telephone No: ..... Fax No: .....

**CONFIRMATION OF APPOINTMENT OF DESIGNER **

PROJECT: .....

**SECTION 1 - To be completed by the Developer**

We hereby certify that we have appointed the firm named in Section 2 below as Designer for this Construction Consent Application.

Name of Developer .....

Address .....  
.....  
.....

Signed .....

Name (print) .....

Date .....  
(for and on behalf of Developer)

**SECTION 2 - To be completed by the Designer**

We hereby confirm that we have been employed by the Developer named at Section 1 above as Designer and that we have carried out sufficient work on the Developer's Design as contained in his Construction Consent Application to satisfy ourselves that the said Design represents a reasonable design to meet the requirements of the Guidelines and all applicable National Standards and Codes of Practice.

Name of Firm .....

Address .....  
.....  
.....

Signed .....

Name (print) .....

Date .....  
(for and on behalf of Design firm)

CHECK CERTIFICATE 

PROJECT: .....

**SECTION 1 - To be completed by the Developer**

We hereby certify that we have employed the firm named in Section 2 below as Checker for the Design contained in our Construction Consent Application.

Name of Developer .....

Address .....  
.....

Signed .....

Name (print) .....

Date .....  
(for and on behalf of Developer)

**SECTION 2 - To be completed by the Checker**

We hereby confirm that we have been employed by the Developer named at Section 1 above as Checker and that we have carried out sufficient work on checking of the Developer's Design as contained in his Construction Consent Application to satisfy ourselves that the said Design represents a reasonable design to meet the requirements of the Guidelines and any applicable National Standards and Codes of Practice.

Name of Firm .....

Address .....  
.....

Signed .....

Name (print) .....

Date .....  
(for and on behalf of Checker)

# SAFETY AUDIT

PROJECT: .....

## STAGE 1/2/3\* ROAD SAFETY AUDIT CERTIFICATE

We hereby certify that a Stage 1/2/3\* Road Safety Audit has been undertaken on the Design as shown and detailed in the following drawings and reports (list relevant drawings and Audit/Exception Reports, any decisions by the arbiter and associated relevant correspondence)

.....  
.....  
.....  
.....

and that all the safety issues raised in the audit report have been addressed by:

- (i)\* incorporating all / some\* of the recommendations of the audit report in the Design  
(Reference: .....\*\*)  
and\*
- (ii)\* adopting alternative solutions that have been agreed by the audit team and have  
been incorporated in the Design  
(Reference: .....\*\*)  
and\*
- (iii)\* incorporating in the Design the decision of the arbitrator (as defined in DMRB) with respect to  
the issues detailed in the exception report  
(Reference: .....\*\*)

Signed ..... Name.....  
(Developer)

Date .....

Signed ..... Name.....  
(Designer)

Date .....

\* Delete as appropriate.  
\*\* Insert report and / or associated correspondence references and report item numbers